

INSTALLATION MANUAL



DOMUS 5000



ALARM SYSTEMS



Nessuna foresta è stata distrutta per produrre questa carta riciclata al 100%.



by GEMINI TRADING S.r.l. Via Luigi Galvani 12 21020 Bodio Lomnago (VA) Italia
Tel. +39 0332 943211 - Fax +39 0332 948080
web site: www.gemini-alarm.com

LIST OF CONTENTS

	PAGE
1.0 SYSTEM DESCRIPTION	4
1.1 TECHNICAL DATA	4
1.2 PERIPHERALS	4
1.3 FRONT PANEL	4
1.4 TERMINAL STRIP	6
2.0 INSTALLATION GUIDE	10
2.1 PRELIMINARY STAGE	10
2.2 CONNECTION TO THE POWER MAINS	10
2.3 REPLACING MAINS FUSES	11
2.4 GROUND CONNECTION	11
2.5 POWERING THE CONTROL UNIT	11
2.6 BATTERY LOW INDICATOR	11
2.7 ACCESS CODES TO THE PROGRAMMING FUNCTIONS	12
2.8 PRIORITY LEVELS	12
3.0. PROGRAMMING THE CONTROL UNIT	13
3.1. ACCESSING THE PROGRAMMING FUNCTION	13
3.2 CHOOSING A LANGUAGE	15
3.3. SETTING THE TIMES	15
3.3.1. Setting the entry time	16
3.3.2. Setting the exit time	16
3.3.3 Setting the alarm time	16
3.3.4 Setting the power outage time	16
3.3.5 Setting sensor and siren checking rates	17
3.4. PROGRAMMING THE WIRELESS LINES	17
3.4.1. CHOOSE ALARM TYPE	17
3.4.2. CHOOSE LINE TYPE	18
3.4.3. AUTOMATIC LINE CUT-OUT	18
3.4.4 COURTESY FUNCTION (CHIME)	19
3.4.5. PRIORITY LEVEL	19
3.4.6. SENSOR CODE LEARNING	19
3.4.7. DOUBLE SENSOR CONFIGURATION	21
3.4.8. LINE CUT-OUT	21
3.4.9. DELETING A LINE	22
3.5. PROGRAMMING THE WIRE LINES	23
3.5.1. SELECTING LINE TYPE	23
3.5.2. AUTOMATIC LINE CUT-OUT	23
3.5.3. COURTESY FUNCTION (CHIME)	24
3.4.5. PRIORITY LEVEL AND CONFIRMING THE SETTINGS	25
3.5.5. CHANGING THE LINE SETTINGS	26
3.5.7. DELETING A LINE	26
3.6. PROGRAMMING THE SIRENS	27
3.6.1. DELETING AND FITTING BACK A SIREN	28

5.0 Technical data

- Power supply	230 Vac - 50/60 MHz
- Current drained in resting conditions	43 mA
- Current drained in alarm condition	120 mA
- Buffer battery	7 Ah 12Vdc
- Minimum radio range	20 m
- Transmission frequency	433.92 MHz
- Dimensions (without the aerial)	275 x 220 x 80 mm
- Weight (with the battery)	1.3 kg

4. Event memory

If any alarms have been detected while the control unit was ON (DAY or NIGHT), when the control unit is switched off the alarm memory becomes active to let you view the last 256 events, complete with date and time. The display shows the message **"PANEL CONTROL OFF"** for a few seconds, followed by the **"SIGNAL EVENTS"** message which stays on the display until you consult the memory or until the control unit is turned on again (DAY or NIGHT).

To indicate that the event memory has been activated, the system gives out 1 beep every 15 seconds. To consult the event memory proceed as follows:

- Enter the user code with priority level 1 (the highest)
- Press the **"clock"** button

The display shows the **"SIGNAL EVENTS"** message for a few seconds, followed by a message concerning the last event memorised. With the **"right arrow"** / **"left arrow"** keys you can view the next/previous event.

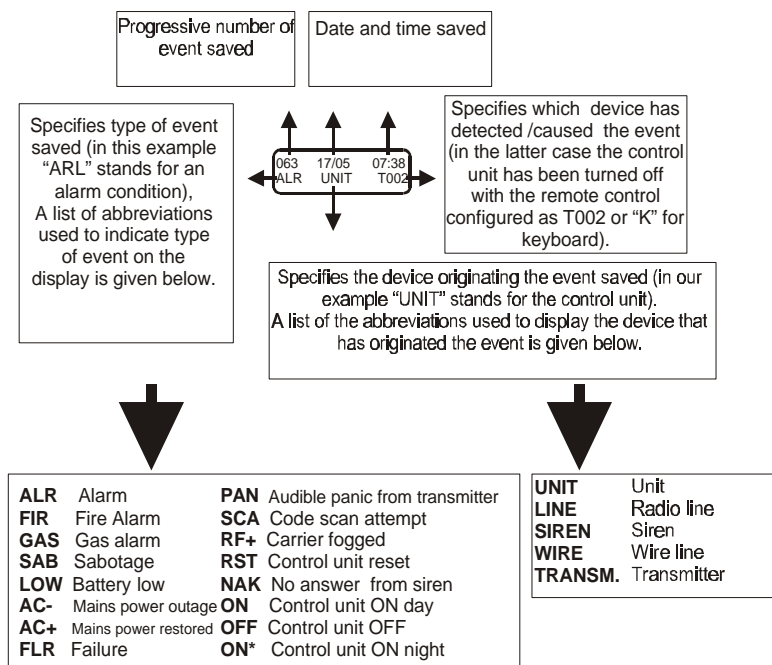

To quit the event memory, press **"OK"**. Domus 5000 shifts to the control unit OFF status (gives out 2 beeps and displays the **"CONTROL PANEL OFF"** message, followed by **"GEMINI TRADING"**).

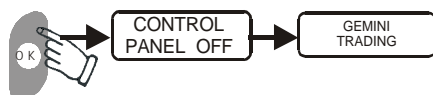

You can consult the event memory any time. Just turn off the control unit and repeat the procedure described above.

3.7	PROGRAMMING THE REMOTE CONTROLS	29
3.7.1.	Deleting and fitting back a remote control	31
3.8.	CHANGING THE TECHNICAL CODE	32
3.9.	CHANGING/ENTERING A USER CODE	33
3.10	TESTING THE SYSTEM	35
3.11.	SETTING THE CLOCK (DATE AND TIME)	37
3.12.	QUITTING THE PROGRAMMING FUNCTION	37
4.	EVENT MEMORY	39
5.0	TECHNICAL DATA	41

1.0 System description

1.1 Technical Data

Domus 5000 is an alarm system equipped with 256 radio lines and 3 balanced wire lines (one of which is active 24 h a day) for protection against theft, fire, gas leaks, burglars. Furthermore, it sends out distress alert calls. The system can be controlled and programmed via an on-board keypad. As an option, it is possible to fit as many as 20 radiocontrols.

Radio transmissions are handled by high precision type-approved modules, ensuring superior immunity to radiofrequency disturbances;

A 16x2 character alphanumeric LCD supplies, in a simple and exhaustive manner, and in real time all the data concerning the status of the alarm system and the peripherals installed, while an event memory displays the last 256 event with date and time. The extreme versatility of DOMUS 5000 lets you select the configuration of each individual line, by setting: alarm condition (theft, fire or gas), immediate/timed, day/night, with or without automatic cut-out after 4 alarm cycles, with or without courtesy function (CHIME).

The alarm system also features countless programmable functions including: periodic monitoring of all peripherals, RF signal defogging system, power mains failure control, entry/exit time, length of alarm stages, audible or silent panic (emergency calls), technical code and 9 user codes (up to 6 digits each) with various system access levels.

1.2 Peripherals

5000IR	-	Infrared ray sensor
5000DT	-	Dual detector
5000CM	-	Magnetic contact
5000CT	-	Blind contact
5000SE	-	External siren
5000COM	-	GSM telephone multiplexer
5000TX	-	Radiocontrol
21/50GAS	-	Gas detector
21/50SM	-	Smoke detector
5000SH	-	Glass breaking contact

1.3 Front panel

The Domus 5000 front panel consists of:

- a keypad
- 2 LED visual indicators (mains power ON and low battery)
- a 16x2 character alphanumeric display
- a plastic base (bottom part)

3.11. Setting the clock (date and time)

To access the control unit clock setting menu, process as follows:

- Start the programming function (see paragraph 3.0) and, by means of the "right arrow" and "left arrow" keys select the "SYSTEM TEST" menu.
- Press the CLOCK button. The will show the date and time message with the first two digits (for the year) blinking.



To gain a better understanding of how to manage the display when the clock has been activated, see the following figure.

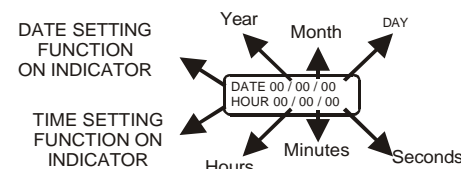

By means of the numerical keypad, set the current year, month, day and time as the relative digits blink on the display.

Having completed the setting procedure, press "OK" to confirm the settings entered. The display shows the "SYSTEM TEST" message again.



3.12. Quitting the programming mode

To quit the programming function, press "OFF". The display shows: "RETURN CTRL PANEL OFF?".

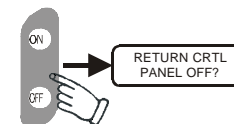

Press "OK" to confirm. 2 beeps are given out and the Domus 5000 shifts to control unit OFF mode (the message "CONTROL PANEL OFF" appears for a few seconds, followed by "GEMINI TRADING").



If the code entered is correct, the message that appears will read: **"CHANGE OK"**, then the display goes to the next menu which lets you change the user code associated with the next priority level.

Repeat the same operations for each code that you wish to change or enter.

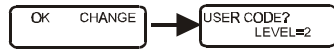

At this point, press **"OFF"** to go back to the **"CHANGE USER CODE ?"** starting menu. By means of the **"right arrow"** or **"left arrow"** keys you can select the other menus. If you wish to quit the programming mode and turn off the control unit, instead, press **"OFF"** again and the **"OK"** (2 beeps are given out, the message **"CONTROL PANEL OFF"** appears, followed by **"GEMINI TRADING"**, which remains on the display).

3.10. Testing of the system

By opening this menu you can perform a test involving the acknowledgement of each peripheral installed (sensors, sirens, remote controls, wire lines, etc.). This procedure makes it possible to check the presence of wireless connections between the individual peripherals installed and the control unit.

To perform the **"SYSTEM TEST"** on each peripheral (sensor, siren, remote control, etc.) you must cause a radio transmission or the opening of a wire line. If the control unit acknowledges a peripheral, it will give out 3 beeps and the display will show both type of peripheral (sensor, remote control, siren, etc.) and the number associated with it. The message concerning the peripheral contacts stays on the display until the next consultation. To gain a better understanding of how the system test works, examine the examples given below:

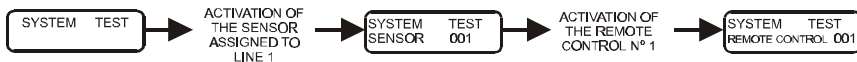

If the peripheral has not been configured, the control unit gives out 1 beep and the display will only show type of peripheral (sensor, remote control, siren, etc.), followed by **"X"**. To gain a better understanding of this stage, see the examples below.

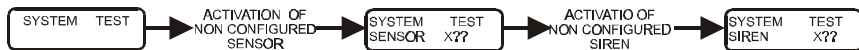

Hence you must activate the menu corresponding to the device to be configured (sensor, remote control, siren, etc.) and program the peripheral according to the instructions provided in the previous pages.

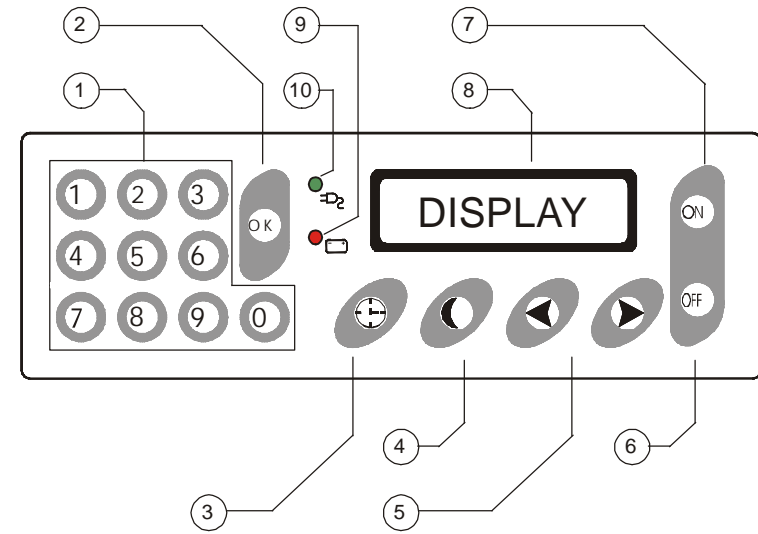

1	Numerical keypad	6 Key to turn off the control unit and cut or delete configured peripherals.
2	Key to confirm selected functions	7 Key to turn On and activation of the line programming function
3	Key to consult event memory, set date and time, and configure the timed lines	8 16x2 character backlit LCD to view all operations and events stored in the memory.
4	Key to shift to night mode and set the peripherals on this mode	9 Internal battery level LED: - ON : LOW - OFF NORMAL
5	Keys to scroll (back and forth) in the various menus	10 Mains power LED: - ON : POWER ON - OFF POWER OFF

1.4 Terminal strip

Remove the front plastic cover by pulling out the two fastening screws. The alarm system enclosure contains a terminal strip as described below:

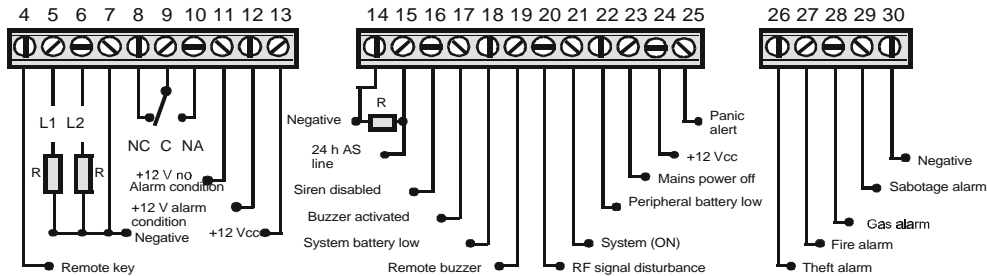

- 4- Remote key. Connect this terminal to the negative to turn on the alarm system in full mode (ON - DAY).
- 5,7- Balanced N.C. line (wire 1 line). Equalising resistance: 12 KOhm.
The line is active with the alarm system ON. Unbalancing initiates an alarm condition.
- 6,7- Balanced N.C. line (wire 2 line). Balancing resistance: 12 KOhm.
The line is active with the alarm system ON. Unbalancing initiates an alarm condition.
- 7- Negative.
- 8,9,10- Normally closed (N.C.) Common (C). Normally open (N.O.). Alarm relay free exchange (I_{max} 5A)
The relay is activated by sabotage, theft, or burglar alarms.
- 11 - +12 Vdc signal present in non alarm conditions (I_{max} 200 mA). The positive signal is cut out by sabotage, theft, burglar, fire or gas alarm conditions. The output can be used to connect self-powered sirens.
- 12- +12 Vdc signal present in sabotage, theft, burglar, fire or gas alarm conditions. The output can be used to connect sirens I_{max} 1.5A).
- 13- Auxiliary output positive signal, +12Vdc (I_{max} 200 mA).
- 14- Negative.
- 14,15- Anti-sabotage balanced N.C. line. Balancing resistance: 12 Kohm. **Line unbalancing initiates a sabotage alarm condition whether the system is ON or OFF (24 h line).**
- 16- Disables wired sirens. Connect to the "Key" terminal of the sirens fitted with this function (silent panic)
- 17- Input activating a buzzer built into the alarm system - (I_{max} 100 mA). The buzzer starts when a negative input is applied to the terminal.

3.9. Changing /entering a user code

This menu lets you change the user codes saved in the Domus 5000 or entering new ones.

CHANGE
USER CODE?

Press "OK" to display a message concerning the selection of the priority level to be associated with the user code in question.

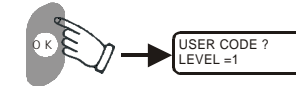

Press the "right arrow" or the "left arrow" key to select the priority level to be associated with the user code in question (the level can be increased from 1 to 9, then it restarts from 1).



Enter a new user code of up to 6 digits. The display will show as many asterisks as the digits entered.

N.B. In the example given below the digits are given in a random manner. If the new code is made of 6 digits, when you have entered the last digit the display shows a prompt: **"REPEAT SEQUENCE"**. If the code is made up of fewer digits, instead, when you have entered the last digit, it is necessary to press **"OK"**. The display will then show the **"REPEAT SEQUENCE"** prompt.

Example of 6-digit code Change

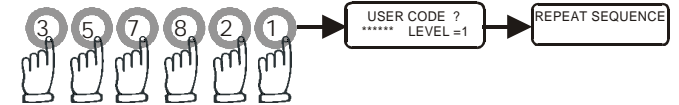

Example of 6-digit code Change



Enter the same code again to confirm your selection.

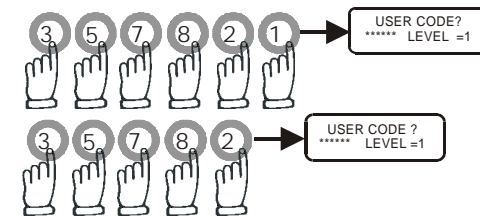

If the code entered is not correct, the display will show the message: **"WRONG SEQUENCE"** for a few seconds and then will show the **"USER CODE ? LEVEL=1"** message again to let you repeat the code change procedure.



3.8. Changing the technical code

This menu is used to change the technical code currently saved in the Domus 5000.

CHANGE
TECHNICAL CODE?

Press "OK" to display the message: "TECHNICAL CODE?".

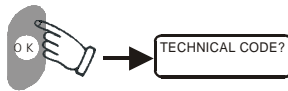

If you wish to quit this menu and go back to the starting menu (**CHANGE TECHNICAL CODE?**), press "OK", otherwise proceed as follows:

Enter a new technical code consisting of up to 6 digits. The display will show as many asterisks as the digits entered.

N.B. In the example given below the digits are given in a random manner.

If the new code is made of 6 digits, when you have entered the last digit the display shows a prompt: "REPEAT SEQUENCE". If the code is made up of a smaller number of digits, when you have entered the last digit, it is necessary to press "OK". The display will then show the "REPEAT SEQUENCE" prompt.

Example of 6-digit code
Change.

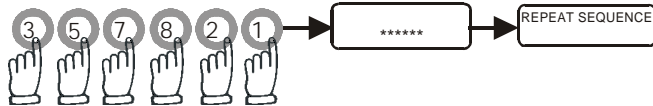

Example of 6-digit code
Change

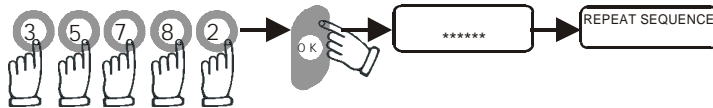

Enter the same code again to confirm your selection. If the code contains fewer than 6 digits, you need not press "OK".

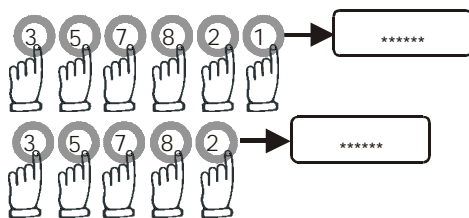

If the code entered is not correct, the display shows for a few seconds the message: "WRONG SEQUENCE", then it goes back to the starting menu to let you repeat the process.



If the code entered is correct, the message that appears will read: "CHANGE OK", then the display goes to the next menu which lets you change the user code.



- 18 - Negative output for system battery low remote indicator (Imax mA)
This output is activated for 30 sec. when battery voltage drops below 10.5 Vdc. This is also indicated on the front panel by the red LED which lights up and stays lit until the battery is recharged. **The output is active with the alarm system On and OFF** and can be used to activate a telephone multiplexer or another unit
- 19 - Negative output for the activation of a remote buzzer which is used to indicate entry & exit times, courtesy function (CHIME), alarm system start & stop - (Imax 100mA).
- 20 - Negative output indicating RF signal disturbances - (Imax 100 mA). The output also communicates sensor or siren failure via radio (see paragraph 3.3.5). **The output becomes active for 30 seconds with the alarm system On and Off** and can be used to activate a telephone multiplexer or another unit.
- 21 - Negative output for alarm system ON remote indication - (Imax 100mA).
- 22 - Negative output for peripheral battery low remote indicator (Imax mA). The output is activated for 30 sec. with the alarm system On and OFF and can be used to activate a telephone multiplexer or another unit.
- 23 - Negative output indicating mains power outage (Imax 100mA). **The output is activated for 30 sec. with the alarm system On and OFF after the time set at the programming stage** has elapsed (see paragraph 3.3.4); it can be used to activate a telephone multiplexer or another unit.
- 24 - Auxiliary output positive signal +12 Vdc (Imax 200mA).
- 25 - Negative output for panic alert indication - (Imax 100mA). **This output can be activated, with the alarm system On and Off, by remote control or from the keypad and stays active for 30 sec.;** it can be used to activate a telephone multiplexer or another unit.
- 26 - Negative output for theft alarm indication - (Imax 100mA). **This output is activated for 30 sec. only with the alarm system ON,** and can be used to activate a telephone multiplexer or another unit.
- 27 - Negative output for fire alarm indication - (Imax 100mA). **This output is activated for 30 sec. only with the alarm system ON,** and can be used to activate a telephone multiplexer or another unit.
- 28 - Negative output for gas alarm indication - (Imax 100mA). **This output is activated for 30 sec. only with the alarm system ON and Off** and can be used to activate a telephone multiplexer or another unit.

- 29- Negative output for sabotage alarm indication - (Imax 100mA).
This output is activated for 30 sec. only with the alarm system ON and Off and can be used to activate a telephone multiplexer or another unit.

- 30- Negative.

CAUTION

If the negative outputs are used for remote LED indicators it is necessary to fit in series with the LED a resistor of from 220 to 4.7 KΩ - ¼ W.

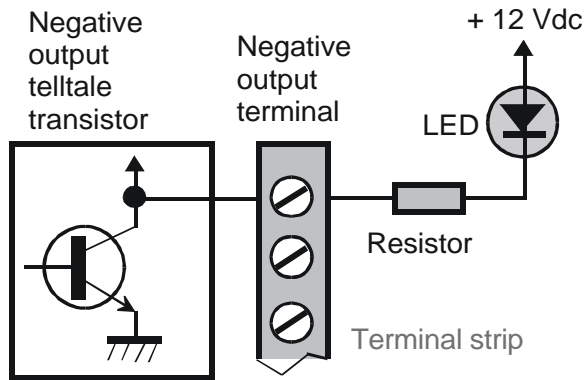

If the indication “**DOUBLE**” is displayed, this means that the transmitter in question has already been programmed in a different position. The control unit gives out a single beep and shows the “**READY**” message again. At this point you must use a different transmitter.

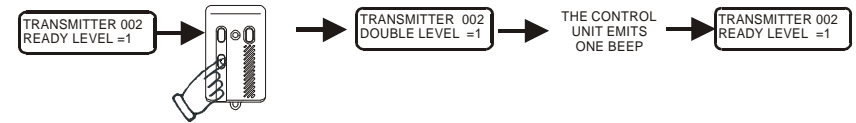

Having completed the remote control programming process, press “**OK**” to return to the main menu: “**PROGRAMMING TRANSMITTERS ?**”.

At this point you have 4 options:

- press “**left arrow**” key to go to the previous menu “**PROGRAMMING SIRENS ?**”
- press the “**right arrow**” key to go to the next menu “**CHANGE TECHNICAL CODE ?**”
- press “**OK**” to re-use the same menu
- press “**OFF**” to display a prompt to return to the control unit OFF mode “**RETURN CTRL PANEL OFF ?**”

3.7.1. Deleting and fitting back a remote control

If it proves necessary to delete a transmitter (e.g., if the transmitter is lost), proceed as follows:

N.B. The example given below concerns the replacement of transmitter n° 1. Go to the transmitter programming menu “**PROGRAMMING TRANSMITTERS?**”, press “**OK**”. The display shows a message saying “**TRANSMITTER 001 OCCUP LIVELLO=X**”. Press “**OFF**”. The display will read “**TRANSMITTER 001 FREE LEVEL =1**”, indicating that the old transmitter has been removed from the control unit memory. At this point, press “**ON**”, and the display will say “**TRANSMITTER 001 CONTROL LEVEL=1**”. At this point, if you wish to change the number assigned to the transmitter or its priority level, otherwise, press the **BLACK** button at the bottom left of the transmitter in question. To confirm that the remote control settings have been saved, the control unit gives out a beep and the display shows the following message: “**TRANSMITTER 001 PROGR LEVEL=1**” and then “**TRANSMITTER 001 OCCUP LEVEL=1**”.

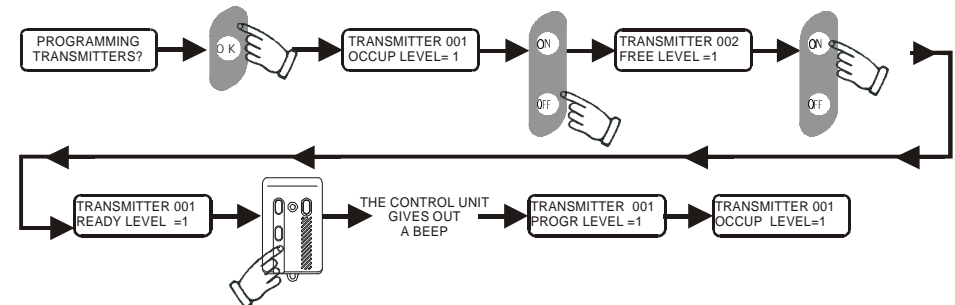

3.7. Programming the remote controls

This menu is used to program the 5000TX remote controls. Domus 5000 accepts up to 20 remote controls with different codes distributed on 9 priority levels.

PROGRAMMING
TRANSMITTERS

Press "OK" to display a message concerning the first remote control.



With the "right arrow" or "left arrow" keys assign a progressive number to the remote control to be configured: 1, 2, 3, 20.



Having reached the desired number, press "ON" to get the control unit to assign a code to the control unit. At this point, the display will show a message: "TRANSMITTER 001 READY LEVEL 1" indicating that the control unit is ready to acquire the code.



With the "right arrow" key select the priority level that wish to assign to the remote control in question (the level can be increased from 1 to 9, then it restarts from 1).



Having reached the desired priority level, the display will read "TRANSMITTER 002 READY LEVEL = X".

At this point, press the **BLACK** button on the remote control. In this manner, the code saved in the remote control microprocessor is transmitted to the control unit. After a few seconds, the Domus 5000 will give out 3 beeps confirming that the code has been learned. The display of the control unit will show for a few seconds a message saying: "TRANSMITTER 002 PROGR LEVEL = X", followed by "TRANSMITTER 002 OCCUP. LE VEL=X". Repeat the same procedure to program the other remote controls.

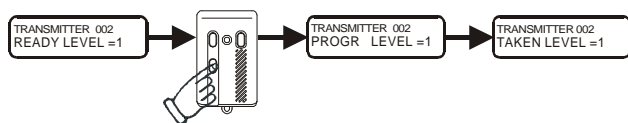

2.0 Installation guide

2.1 Preliminary stage

The first thing to be done is to determine the number and arrangement of the peripherals to be installed on the basis of the characteristics of the rooms to be protected (e.g. number of doors and windows, presence of balconies and terraces, storey, etc.). These decisions in their turn will determine the location of the control unit, for which we recommend taking into account the following criteria:

- Install the unit in a central position relative to the peripherals. If the system includes the protection of a multi-storey building, install Domus 5000 at a level corresponding to half the height of the building (e.g., in a three-storey building, install the control unit in the first floor).
- Position the unit about 1.5 m above the floor and do not run any electric cables within a distance of ca 1.5 m from the unit.
- Do not ever install the unit in the proximity of inductive loads (electric motors and the like), on metal or reinforced concrete walls, on walls adjacent to the elevator shaft or in the immediate proximity of big metal masses.

To get the control unit ready for installation, first of all remove the front panel by removing its two fastening screws.

2.2 Connection to the power mains

Before making the connection to the household power mains, **make sure that the end parts of the wires (that come in contact, i.e. are not protected) are carefully inserted into terminals 1 and 3, as shown in the figure. If desired, use pre-insulated terminals.**

The connection is indicated by the lighting of a green LED on the panel. If the power is cut off, the green LED goes out and a dedicated output (terminal 23) is activated for 30 sec. after the time set at the programming stage has elapsed (see paragraph 3.3.4).

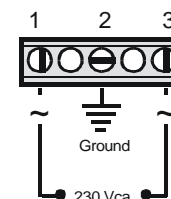

CAUTION

Before performing ordinary maintenance operations, cut out the 230 Vac power supply. To this end, when the control unit is installed, it is necessary to equip the electrical system of the building with an omnipolar sectioning device that will open the contacts by at least 3 mm.

2.3 Replacing mains fuses

One of two phases coming from the mains is protected by a T400 mA delayed fuse located in the left part of the power supply system. In the event of a failure, the fuse can be easily removed with the aid of a screwdriver: push in the fuse box cap, turn it by 90°, either clockwise or counterclockwise (see figure) to snap it out of its housing and pull it out together with the fuse.

Replace the fuse with another the same size (amperage) and fit back the cap by repeating the same process in reverse order.

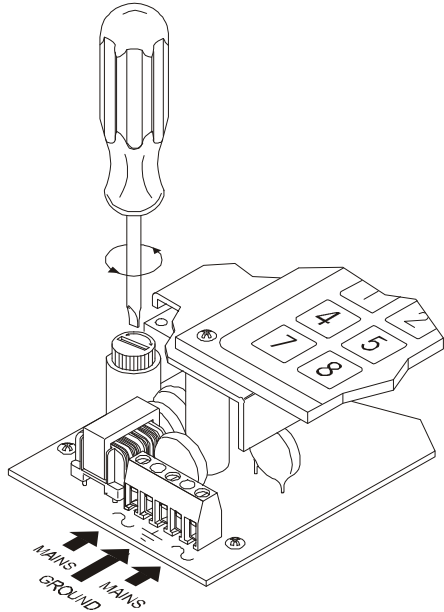

2.4 Ground connection

To ensure optimal control unit operation and maximum safety for the users, we recommend connecting the system to an effective **ground socket**.

2.5 Powering the control unit

When Domus 5000 is powered for the first time, set it on OFF: the display will show the message "GEMINI TRADING".

If (mains and battery) power is cut off, upon being powered again the control unit will return to the same conditions it was in at power off. If the power outage persists for several days, the settings of the control unit and all programmed functions are maintained in the memory, but the internal clock stops. Accordingly, at power up it becomes necessary to reprogram the date and time so as to enable the control unit to supply correct information on the events detected.

3.6.1. Deleting and fitting back a siren

If a previously configured siren is removed from the system for maintenance or failure, do not forget to delete it from the configuration, otherwise the control unit will notice that the siren checking signal is missing and will activate the output at terminal 20.

To delete a siren from the system, proceed as follows:

Go to the siren programming menu

Press "OK"

Select the siren to be deleted

Press "OFF".

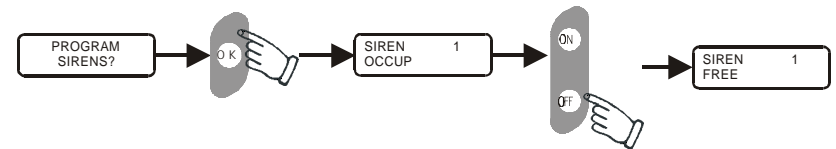

When the siren is reinstalled, repeat the configuration and code learning processes. Having completed the programming sequence, press "OK" to go back to the main menu "PROGRAMMING SIRENS?".

At this point you have 4 options:

- press the "left arrow" key to go to the previous menu "PROGRAMMING WIRE LINES ?"
- press the "right arrow" key to go to the next menu "PROGRAMMING TRANSMITTERS?"
- press "OK" to re-use the same menu
- press "OFF" to display a prompt to return to the control unit OFF mode: "RETURN CTRL PANEL OFF ?"

3.6. Programming the sirens

This menu concerns the configuration of the 5000SE radio sirens to be combined with Domus 5000. You can configure up to 3 sirens with different codes.



Press "OK" to display a message concerning the first siren.



With the "right arrow" and "left arrow" keys you can select the siren to be programmed: 1, 2 or 3.



Programming procedure (to be performed with the siren open)

Press "ON". The control unit is ready to learn the code of the siren in question:



- Make sure that the siren is not powered (turn off the battery and the power supply unit).
- On the siren, set dip switches 5 and 6 on "ON" and dip switch 7 on "OFF".
- Power the siren.
- After a few seconds, a beep is given out and the siren starts blinking; this is followed by 3 beeps given out by Domus 5000. To confirm that the code has been saved, the display of the control unit briefly shows a message saying "SIREN 1 PROGR", followed by "SIREN 1 OCCUP".

CAUTION: reset dip switch 5 on "OFF" to enable the siren to start working.

Repeat the same procedure for the other sirens.

When the message "SIREN 2 PROGR" is followed by another message saying "SIREN 2 DOUBLE" this means that the siren in question had already be configured in a different position. In this case, the control unit gives out a single beep and shows the message "SIREN 2 READY AGAIN". Use another siren and repeat the procedure. sirena e ripetere la procedura.



When the display shows the message "SIREN X FREE", press "OK" to return to the starting menu, "PROGRAM SIRENS?". Then, by means of the "right arrow" or "left arrow" keys you can go to either the previous or the next menu.

2.6 Battery low indicator

When the control unit battery voltage drops below 10.5 Vdc, a red LED is activated on the front panel and stays lit until battery charge is restored (active only with mains power off).

Furthermore, a dedicated output (terminal 18) is activated for 30 sec.; this can be connected to a telephone multiplexer.

If the voltage decreases even further down to 7.5 Vdc the display goes out and all outputs in the terminal strip are deactivated so as to prevent the battery from being totally discharged and then be damaged when the mains power is restored.

It should be noted that Domus 5000 has been designed so that even, if the outputs are deactivated, no alarm signal is transmitted to the sirens via wire.

2.7 Access codes to the programming functions

Two access codes, a **technical code** and a **user code**, are used to prevent unauthorised people from accessing the control unit configuration functions and a number of protected zones of Domus 5000.

Each code may consist of from a minimum of one digit to a maximum of six digits, thereby making it possible to set up to 1,111,110 different codes.

Technical code - This is the code that gives access to the programming functions. Without this code it proves impossible to access the configuration menu.

User code - This code is used by the user to manage the system and program the control unit.

2.8 Priority levels

The Domus 5000 control unit envisages 9 priority levels for partial system deactivation. This means that one or more lines configured for a given level can be deactivated only by means of a remote control or a keypad code configured for the same priority level or higher. The 9 priority levels are:

Priority level 1 - The level 1 user code can deactivate the entire system. It is the only code that makes it possible to have access to the event memory and the control unit programming function (if preceded by the technical code).

Priority level 2 - This code can only deactivate the lines configured for the same level (2) or lower; it cannot deactivate level 1.

Priority level 3 - This code can only deactivate the lines configured for the same level (3) or lower; it cannot deactivate levels 1 and 2.

Priority level 8 - This code can only deactivate the lines configured for the same level (8) or lower; it cannot deactivate the higher levels.

Priority level 9 - This code can only deactivate the lines configured for the same level (9) or lower; it cannot deactivate the higher levels.

CAUTION

Total or partial system deactivation is determined by the priority level at which it is performed, whilst the activation is always total, regardless of which priority level is it performed at.

Domus 5000 is supplied as standard with the following pre-set codes:

Technical code: 5 5 5 5 5
User code with priority level 1: 1 2 3 4 5 6

Pre-set codes can be changed at any time following the ad hoc procedures (see paragraphs 3.8 and 3.9), while the user codes with priority levels from 2 to 9 have to be set by the users.

3.5.5. Changing the line setting

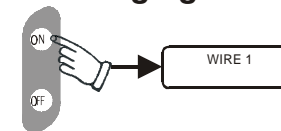

Press "ON" to return to the line programming menu and make any changes you may wish to introduce (follow the procedures described in paragraph 3.5).

3.5.6. Line cut-out

This function is used when, for any reason, you want any line to be provisionally cut out from the system. Press "OFF" to cut out the line.

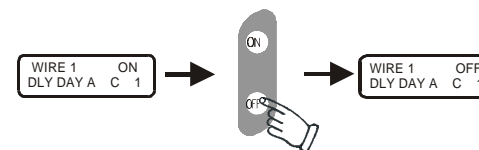

Press "ON" to activate the line again.

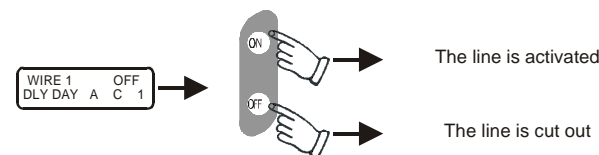

3.5.7. Deleting a line

Press the "OFF" key twice consecutively to delete a line: the display will show a message saying "WIRE 1". At this point, the line is ready to be configured again.

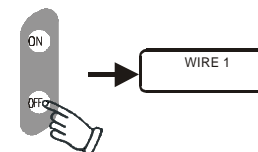

Having completed the programming of the wire lines, press "OK" to go back to the main menu: "PROGRAMMING WIRE LINES".

Now you have 4 options:

- press the "left arrow" key to go back to the previous menu "PROGRAMMING SENSORS ?"
- press the "right arrow" key to go on to the next menu "PROGRAMMING SIRENS ?"
- press "OK" to re-use the current menu.
- press "OFF" to display a prompt to return to the control unit OFF mode: "RETURN CTRL PANEL OFF ?"

The message that appears on the display makes it possible to activate/deactivate the chime function. Press the **"right arrow"** key to make your selection and the **"OK"** key to confirm your choice and go on to the next message.

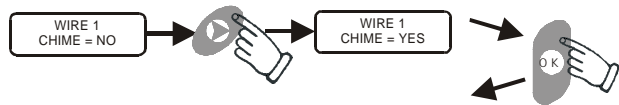

3.5.4. Priority level and confirming the settings

As described in paragraph 2.8. Domus 5000 has 9 priority levels. This applies to the 2 wire lines as well.

With the **"right arrow"** key you can increase the priority level from 1 to 9, and then restart from 1.

Having reached the desired priority level, press **"OK"** to confirm the configuration of the line.

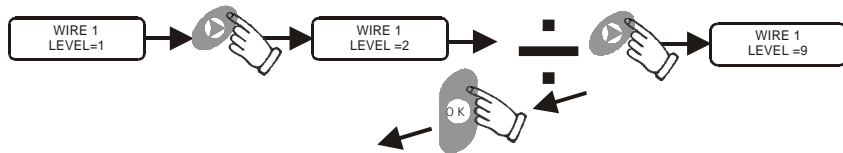

The display will show, for a few seconds, a message concerning the new configuration of wire line 1.

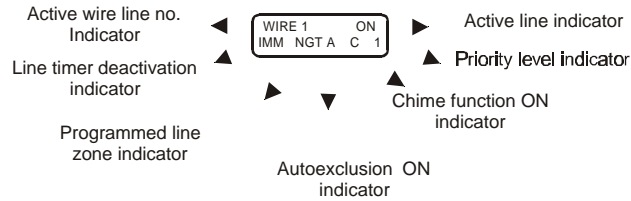

- WIRE 1** = Line 1 configured
- ON** = Line ON
- IMM** = Immediate line
- NGT** = Night line
- A** = can be cut out automatically after 4 alarm cycles
- C** = "Chime" function ON
- 1** = Priority level 1 (highest)

To program the next line, press the **"right arrow"** key. The display will show the following message:

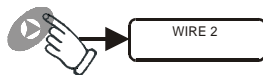

To configure the **"WIRE 2"** line, repeat the same steps as per paragraph 3.5.1.
N.B. The 24h wire line cannot be programmed: it is available for round-the-clock protection.

3.0. Programming the control unit

3.1. Accessing the programming function

- First connection to the mains

Once it has been connected to the household mains and powered, the control unit displays for a few seconds the **"PANEL CONTROL OFF"** message and gives out two audible signals (beeps), then it displays the message **"GEMINI TRADING"**.

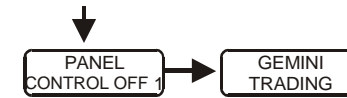

- Entering the technical code

To gain access to the control unit configuring function, enter first the technical code and then the top priority user code. This is done to prevent unauthorised persons from accessing the control unit and changing the settings while the system owner is away. The code pre-set in the factory is **"555555"**. The display will show as many asterisks as the digits entered. Press **"OK"** to confirm the code entered. If the code entered is correct, the display will show a prompt: **"USER CODE?"**.

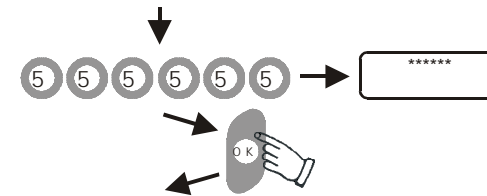

- Entering the priority 1 user code

The code set in the factory is **"12345"**. The display will show as many asterisks as the digits entered. Press **"OK"** to confirm. If the code that you have entered is correct, the display shows a welcome message for a few seconds, an audible signal (beep) is given out, and the programming functions become available. The first menu that appears is the one that lets you choose a language.

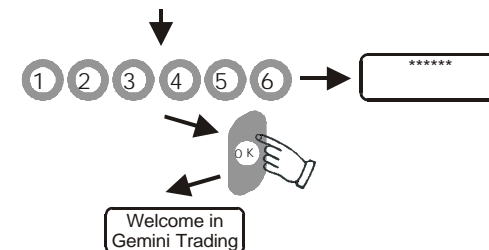

The programming procedures of each individual menu are described in the following paragraph.

In this figure you can see the general programming controls

By pressing on the “left arrow” and “right arrow” keys you can move to the previous or next menu, respectively.

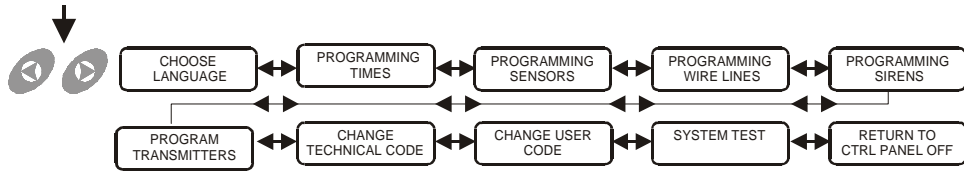

Press OK to access the functions of the chosen menu.



You can quit the programming stage any time, by following the instructions provided in paragraph 3.12.

3.5. Programming the wire lines

This menu concerns the configuration of the two balanced wire lines for protection against theft. If you wish to use this menu, press "OK". The display will show a message saying: "WIRE 1".

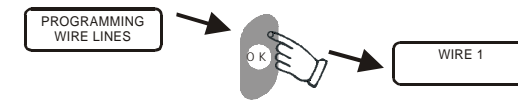

3.5.1. Selecting line type

Press "ON" to configure the line. The display will read: "WIRE 1 IMMEDIATE DAY".

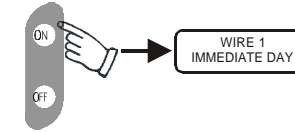

Press the clock button to select line type: whether immediate or timed.



Press the key with the moon to select the day/ night split. Press "OK" to confirm your selection and go on to the next message.

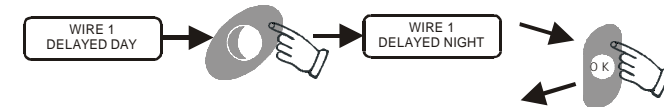

3.5.2. Automatic line cut-out

This function makes it possible to cut out a line automatically after 4 consecutive alarms. Press the "right arrow" key to activate/deactivate this function. Press "OK" to confirm your choice and go on to the next message.

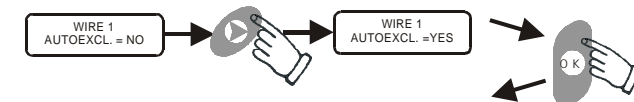

3.5.3. Courtesy function (CHIME)

Either line can also be configured for the chime function. In this manner, with the control unit off, each time the area protected by this line is encroached on, the buzzer built into the control unit gives out 3 beeps and so does the remote buzzer connected to terminal 19 (if fitted).

With the control unit ON, any intrusion into this area triggers an alarm.

Press "ON" to activate the line again

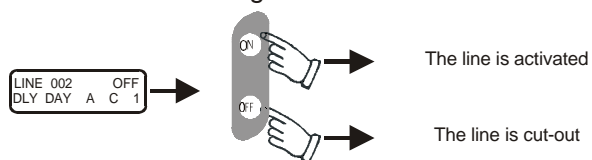

3.4.9. Deleting a line

Press the "OFF" key twice consecutively to delete a line: the display will show a message saying "LINE 001". At this point, the line is ready to be configured again.

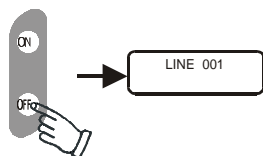

Non configured lines are not considered. Accordingly they are never listed or displayed.

Having completed the programming of the radio lines, press "OK" to go back to the main menu, where the following prompt is displayed:

"PROGRAMMING SENSORS ?".

Now you have 4 options:

- press the "left arrow" key to go back to the previous menu
"PROGRAMMING TIMES ?"
- press the "right arrow" key to go on to the next menu
"PROGRAMMING WIRE LINES ?"
- press "OK" to re-use the current menu.
- press "OFF" to display a prompt to return to the control unit OFF mode: **"RETURN TO CTRL PANEL OFF ?"**

3.2. Choosing a language

A few seconds after the visualisation of the welcome message, the display shows the first programming menu, i.e. the one that lets you choose a language.



The language used as default is Italian. If you do not intend to use a different language, press the "right arrow" key to go on to the next menu. Otherwise:

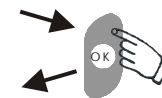

Press "OK" to display the current language. The display will show the following message:



To set a language other than the current one, press the "right arrow" key several times. The display will show the language options (Italian, English, French and German) in this order. The Italian and the English versions are available at present.



When the desired language appears, press "OK". Your selection is saved and the display will show the next menu in the chosen language.

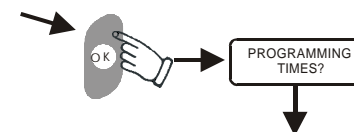

3.3. Setting the times

The second menu that appears lets you set the times



Domus 5000 is supplied with the following time settings, configured in the factory:

ENTRANCE TIME	= 15 seconds
EXIT TIME	= 30 seconds
ALARM TIME	= 60 seconds
ENTRANCE TIME	= 15 seconds
MAINS RAIL TIME	= 60 minutes
VERIFY SENSOR TIME	= 12 hours

3.3.1. Setting the entry time

The entry time is the time period elapsing between the reception, by the control unit, of an alarm from the timed lines and the activation, again by the control unit, of the siren and telephone multiplexer (if fitted). During this time period the buzzer built into the alarm system gives out 1 beep per second, and so does the remote buzzer connected to terminal 19 (if fitted). Press "OK" to view the message concerning the length of the entry time set for the lines configured as timed lines

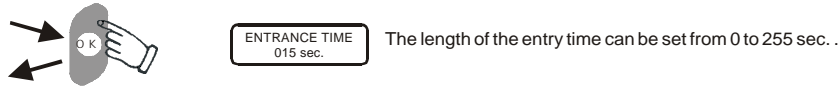

The duration of the entry time can be modified by pressing the "right arrow" and the "left arrow" keys. With the "right arrow" key the time is increased, and with the "left arrow" key it is decreased. Keep either key pressed to speed up the increment or increment.



Press "OK" to display the new setting and view the next message.

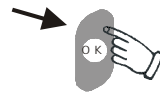

3.3.2. Setting the exit time

The exit time is the time interval elapsing between power up and the time when the sensors configured as timed sensors are actually activated. This time can be modified through the same procedure as described in paragraph 3.3.1. The length of the exit time can be set from 0 to 255.

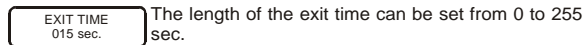

Press "OK" to save the new setting and view the next message. During the exit time, the remote buzzer connected to terminal 19 (if fitted) gives out 1 beep per second.

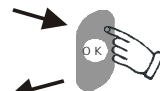

3.3.3. Setting the alarm time

The third message concerns the alarm time. This value can be changed through the same procedure as described in paragraph 3.3.1.

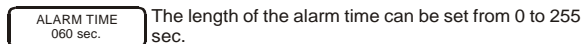

3.4.7. Double sensor configuration

Each Domus 5000 line can manage a single code coming from the sensors. If you attempt to configure two different lines with two sensors having the same code, the control unit will notify the anomaly as follows:

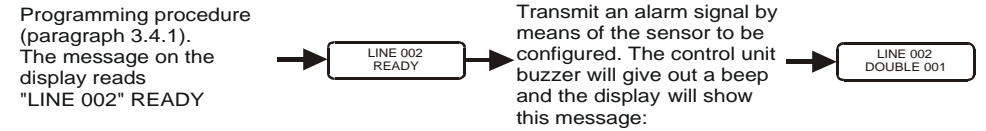

The meaning of the messages appearing on the display is as follows:

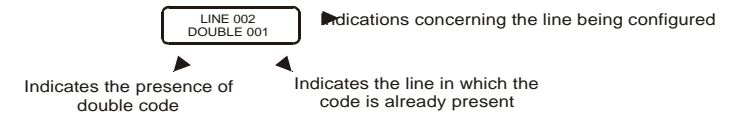

To go back to the learning procedure for the chosen zone, press "OK": a message saying "LINE 002 READY" will appear on the display.



To configure the line properly, proceed as follows:

- Change the code on the sensor (rearrangement of the dip switches)
- Generate an alarm signal from the sensor to be configured.
- The saving of the code transmitted is notified with 3 beeps and by the simultaneous appearance on the display of a message saying "LINE 002 PROGR"; this is followed, after a few seconds, by a message concerning the configuration of the line in question.



3.4.8. Autoexclusion

This function is used when, for any reason, you want any line to be provisionally cut out from the system. Press "OFF" to cut out the line.

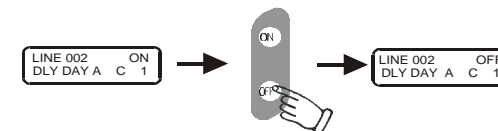

The appearance of a message saying "**LINE 001 READY**" tells you that the control unit is ready to learn the code transmitted by the sensors via radio.

LINE 001
READY

Transmit an alarm signal by means of the sensor whose code has to be memorised. The emission of 3 beeps and the simultaneous appearance of a message saying "LINE 001 PROGR" confirm that the code transmitted has been learned.

LINE 001
PROGR.

The display will also show the indications concerning the configuration selected for the line. To gain a better understanding of the messages supplied by the display, examine the example shown below.

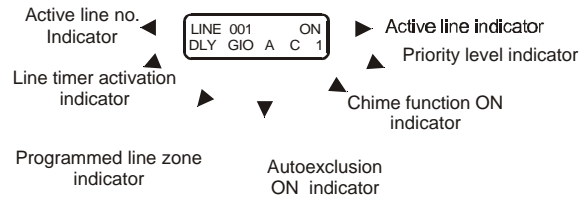

- LINE 001** = Line 1 configured
- ON** = Line ON
- DLY** = Timed line
- DAY** = Day line
- A** = can be cut out automatically after 4 alarm cycles
- C** = "Chime" function ON
- 1** = Priority level 1 (highest)

To program the next line, press the "**right arrow**" key. To program or check the previous line, press the "**left arrow**" key (for the code learning procedure, see paragraph 3.4.1).

The display will show the following message:

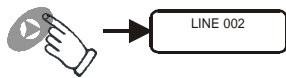

Press "**OK**" to save the desired setting and go on to the next message.

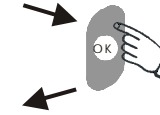

3.3.4. Setting the mains fail time

The fourth message concerns the intervention time in the event of a mains power outage. When this time period has elapsed, the dedicated output (terminal 23) is activated for 30 seconds. This value can be changed through the same procedure as described in paragraph 3.3.1.

MAINS FAIL
TIME 060 min. The length of the power outage time can be set from 0 to 255 sec.

Press "OK" to save the desired setting and go on to the next message.

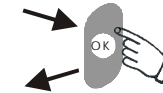

3.3.5. Setting sensor and siren time (Periodic supervision)

VERIFY SENSOR
TIME 012 hours The length of the sensor checking rate can be set from 1 to 24h.

When ON, the siren and the sensors are constantly monitored by the control unit, as follows:

- **Sensors:** the sensors transmit signals to the control unit at regular intervals to confirm their regular operation and indicate low batter level.
- **Sirens:** the sirens communicate with the control unit through a special two-way communication protocol. The exchange of data takes place every 30 min. If the control unit does not receive the signals from the various peripherals, it notifies the problem as follows:
 - **Sensors:** a "**SENSOR FAILURE**" message appears on the display
 - **Sirens:** a "**SIREN NAK**" message appears on the display.
 In either case, in addition to the messages on the display, a dedicated output (terminal 20) is activated for 30 sec. The sensor checking frequency can be modified as described in paragraph 3.3.1.

Press "**OK**" to save the desired sensor checking rate and go on to the next message.

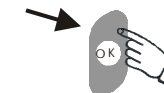

3.4. Programming the wireless lines

The next menu that appears on the display lets you configure the sensors to be installed in the 256 radio lines. To save the settings for the sensors installed we recommend using the line configuration table given at the end of the "USER MANUAL". This instrument proves useful when you work on the system again for maintenance purposes or when you have to fit additional peripherals.

PROGRAMMING SENSORS?

Press "OK" to view the message concerning the line 1.

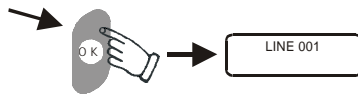

3.4.1 Choose alarm type

Press the "ON" key to activate the line that has to be programmed. Press the "right arrow" key until the display shows the type of alarm burglary fire, gas) that you wish to assign to the line in question.

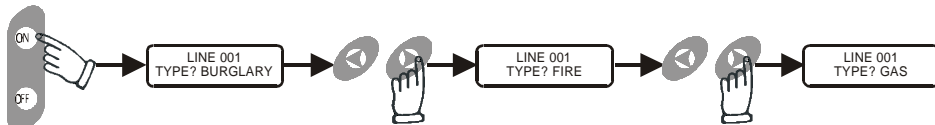

Press "OK" to confirm your selection and go on to the next message.

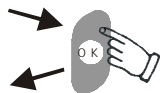

LINE 001 TYPE? BURGLARY In this case line 1 has been assigned to theft.

- **Warning:** if the line is associated with the fire or gas alarm, the system goes on directly to the sensor automatic learning menu (see paragraph 3.4.6.).

3.4.2. Choose line type

Press the button with "clock" symbol to select line type: immediate or timed.



If you press the "moon" button, instead, you can select the line split option: DAY or NIGHT. Press "OK" to confirm your selection and go on to the next message.

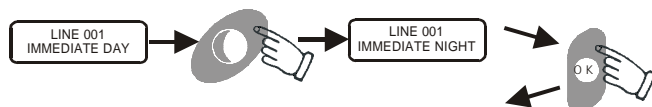

3.4.3. Automatic line autoexclusion

This function makes it possible to cut out the line after 4 consecutive alarms. Press the "right arrow" key to activate/deactivate this function. Press "OK" to confirm your choice and go on to the next message.

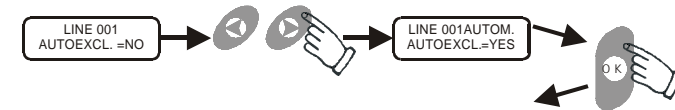

3.4.4. Courtesy function (CHIME)

The line can also be configured for the chime function. In this manner, with the control unit OFF, each time the area protected by this line is encroached on, the buzzer built into the control unit gives out 3 beeps and so does the remote buzzer connected to terminal 19 (if fitted).

With the control unit ON, any intrusion into this area triggers an alarm. The message that appears on the display makes it possible to activate/deactivate the chime function. Press the "right arrow" key to make your selection and the "OK" key to confirm your choice and go on to the next message.

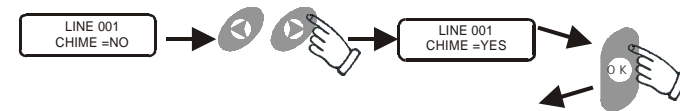

3.4.5. Priority level

As described in paragraph 2.8., Domus 5000 has 9 priority levels for the activation/deactivation of the various lines. With the "right arrow" key you can increase the priority level (from 1 to 9), while with the "OK" key you can confirm the chosen level and go on to the next message.

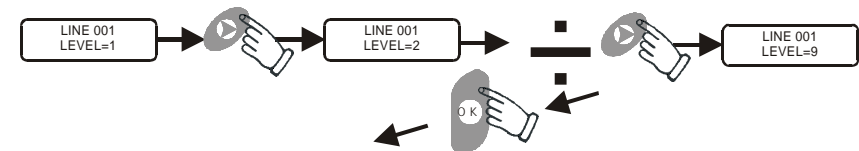

3.4.6. Sensor code learning

Each Domus 5000 sensor is equipped with a dip switch with 8 or 9 shunts (depending on the sensor). By positioning the first 8 shunts, we get 256 transmission codes to the control unit. When a sensor is activated a code is transmitted to the control unit, which therefore can learn it.

Domus 5000 learns and saves the code transmitted by each sensor but will not accept the same code on two different lines or two codes on the same line. Hence, each line can be associated with one sensor and only that one.