

INSTALLATION CERTIFICATE

The undersigned qualified installer attests to have personally fitted the here described vehicle security system following the manufacturer instructions.

By :

Sold on :

- Type of product : 863 - 863/24
 862
 861

Vehicle :

GEMINI Technologies S.r.l.
Via Luigi Galvani 12 - 21020 Bodio Lomnago (VA) - Italy
Tel. +39 0332 943211
www.gemini-alarm.com
ISO 9001 Certified Company



863 - 863/24
862
861

**INSTALLATION AND
USE MANUAL**



Made in Italy

AC2710/UK Rev.05 - 03/22

| | |
|---|---------|
| 1.0 - PRELIMINARY ADVICE | PAGE 03 |
| USER MANUAL | |
| 2.0 - OPERATING DESCRIPTION | PAGE 03 |
| 2.1 - System total arming..... | PAGE 04 |
| 2.2 - System arming in mute mode..... | PAGE 04 |
| 2.3 - System partial arming..... | PAGE 04 |
| 2.4 - Passive arming..... | PAGE 04 |
| 2.5 - Arming delay..... | PAGE 04 |
| 2.6 - System armed..... | PAGE 05 |
| 2.7 - Alarm, neutral time between alarms and alarm cycles..... | PAGE 05 |
| 2.8 - System disarming..... | PAGE 05 |
| 2.9 - Alarm memory..... | PAGE 05 |
| 3.0 - PIN CODE CUSTOMIZATION | PAGE 06 |
| 4.0 - EMERGENCY OVERRIDE VIA PIN CODE | PAGE 07 |
| 5.0 - VALET MODE | PAGE 07 |
| INSTALLER MANUAL | |
| 6.0 - CONNECTOR PINOUT | PAGE 08 |
| 7.0 - CONNECTION FOR TURN SIGNALS ACTIVATION | PAGE 08 |
| 8.0 - WIRING DIAGRAM | PAGE 09 |
| 9.0 - PROGRAMMABLE FUNCTIONS | PAGE 10 |
| 9.1 - Acoustic signals..... | PAGE 10 |
| 9.2 - Panic alarm or car finder..... | PAGE 10 |
| 9.3 - Current absorption sensor..... | PAGE 10 |
| 9.4 - Anti-distraction rearming and auto-lock..... | PAGE 10 |
| 9.5 - Passive arming..... | PAGE 10 |
| 9.6 - Door Lock/Unlock time delay..... | PAGE 10 |
| 9.7 - Comfort control..... | PAGE 10 |
| 9.8 - Double pulse unlock..... | PAGE 10 |
| 9.9 - Additional siren output or boot release..... | PAGE 10 |
| 9.10 - Negative output selection (during alarm) for horn or additional siren..... | PAGE 10 |
| 9.11 - Door open warning signal during arming..... | PAGE 10 |
| 9.12 - Optical signaling mode..... | PAGE 10 |
| 9.13 - Door switch polarity selection..... | PAGE 11 |
| 10.0 - SYSTEM PROGRAMMING | PAGE 11 |
| 11.0 - PROGRAMMING NEW DEVICES | PAGE 12 |
| 12.0 - DELETING PROGRAMMED DEVICES | PAGE 13 |
| 13.0 - ULTRASONIC VOLUMETRIC PROTECTION | PAGE 14 |
| 13.1 - Connection and positioning..... | PAGE 14 |
| 13.2 - Sensor adjustment..... | PAGE 14 |
| 14.0 - SYSTEM RESET | PAGE 14 |
| 15.0 - TECHNICAL SPECIFICATIONS | PAGE 15 |
| 16.0 - WASTE ELECTRICAL AND ELECTRONIC EQUIPMENT | PAGE 15 |

1.0 - PRELIMINARY ADVICE

Dear Customer, the present manual illustrates the most fully featured alarm system; not all functions, electrical connections, etc. will therefore apply to all models. Before installing, identify your alarm model and refer to it for the correct instructions.

862: same as 863 without self-powered battery.

861: same as 862 without override key, engine block, comfort feature and positive output with system armed (+A).

The following signs are used throughout the manual to emphasize important instructions or special information:



For the user.
This sign highlights useful information.



For the installer.
This sign indicates that the system will work according to the connections and the programming selected or it simply provides useful installation tips.

USER MANUAL

2.0 - OPERATING INSTRUCTIONS

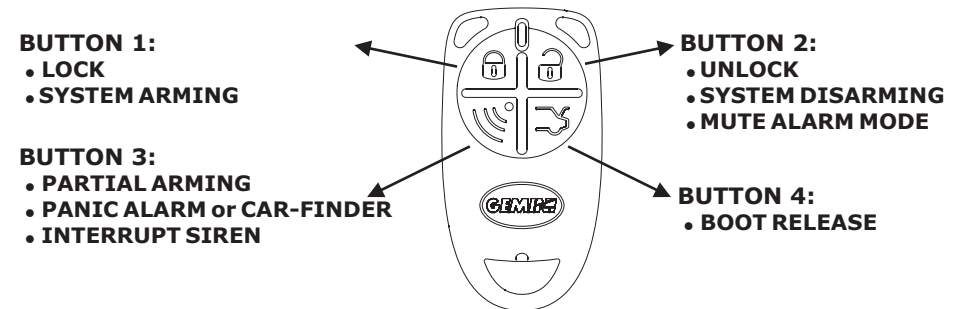

If the LED flashes at the press of a button, the battery is weak and must be replaced as follows:

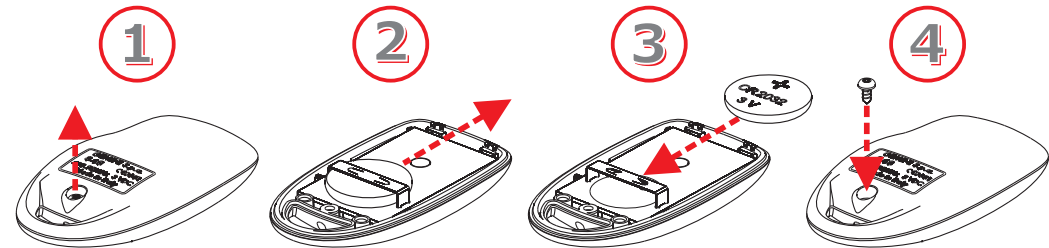



Use only CR2032 batteries. Risk of explosion if battery is replaced by an incorrect type.
Discard used batteries properly in special dedicated containers.

2.1 - SYSTEM TOTAL ARMING

Press remote control button 1  or touch the override key to its receptacle. System arming is confirmed by 2 Beeps and 2 flashes of the turn indicators. The system has a 35 sec. arming delay during which the LED indicator is ON steady.

2.2 - SYSTEM ARMING IN MUTE MODE

The system can be armed in mute mode so that the siren does not sound when an alarm is triggered. To exclude the siren, proceed as follows:

- With the alarm system disarmed, turn ignition key to ON; the status LED will light up for approx. 1 sec.
- While the LED is ON, press remote control button 2 .
- Exit the vehicle and press remote control button 1 .
- Arming will be confirmed by 2 Beeps and 2 flashes of the turn indicators.
- The siren will not sound when an alarm is triggered.



Siren exclusion is bound to a single arming cycle.





The additional siren negative output (YELLOW-BLACK wire) will not be excluded so that auxiliary modules (trackers, etc.) can be managed in the event of an alarm.

2.3 - SYSTEM PARTIAL ARMING

The system can be armed without activating the volumetric protection, the external sensors (wireless infrared or wireless hyper-frequency), the positive output with system armed (+A) and the comfort feature.

To exclude the above functions proceed as follows:

- Make sure the system is disarmed and ignition key is in the OFF position;
- Press remote control button 1 ; the system will arm with 2 Beeps and 2 flashes of the turn indicators.
- During the arming delay, press remote control button 3 .
- The turn indicators will give a quick flash and the LED will turn off for 1 sec. to confirm exclusion.



Exclusion is bound to each single arming cycle.

2.4 - PASSIVE ARMING

When passive arming is enabled, the system automatically arms approx. 30 sec. after ignition is switched OFF and after the last door is opened and closed. Passive arming is confirmed by 1 flash of the turn indicators, 2 LED flashes and 2 Beeps.



Opening a door during the 30 sec. arming countdown will cause the procedure to interrupt; it will resume once the door is closed. When the system arms passively, interior protection and comfort output (automatic window roll-up) are excluded.

2.5 - ARMING DELAY

The arming delay lasts approx. 35 sec. and is signaled by the status LED ON steady. The delay time allows you to exit the vehicle after arming the system without setting off an alarm.

2.6 - SYSTEM ARMED

After the arming delay the system is fully armed and ready to detect any alarm event. The LED will start flashing to confirm the armed status.

2.7 - ALARM, NEUTRAL TIME BETWEEN ALARMS AND ALARM CYCLES

Alarm events are signaled by optical/acoustic signals. When the alarm is over, there is a 5 sec. interval before another alarm can be triggered to allow disarming the system via the PIN override code (see par.4.0).

Each alarm event can generate up to eight 30-sec. cycles for each input and for each arming cycle. Only the "ignition attempt" and the "wire tampering" alarms have no limits.



An alarm cycle can be stopped without disarming the system by pressing remote control button 3.

2.8 - SYSTEM DISARMING

Press remote control button 2  or touch the override key to its receptacle, disarming is confirmed by 3 Beeps and 3 flashes of the turn indicators.

An alarm event detected while the system is armed will be signaled upon disarming by 5 flashes of the turn indicators and 5 Beeps.

2.9 - ALARM MEMORY

The LED memory allows to identify the last alarm event signaled by 5 flashes of the turn indicators and 5 Beeps when the system is disarmed.

Turn ignition key in ON, the status LED will flash according to the last alarm detected prior to disarming (see table below).

The flash sequence is repeated 5 times; to interrupt turn ignition key OFF.

| LED FLASHES | ALARM CAUSES | ALARM CYCLES |
|---|--|--------------|
| * * ● * * | Ignition attempt (+15/54) | Unlimited |
| * * * ● * * * | Door tamper | 8 |
| * * * * ● * * * * | Bonnet tamper or external sensors | 8 |
| * * * * * ● * * * * * | Internal sensor | 8 |
| * * * * * * * ● * * * * * * * | Wireless magnetic contact | 8 |
| * * * * * * * * ● * * * * * * * * | Wireless infrared sensor (PIR) or wireless hyper-frequency | 8 |
| * * * * * * * * * ● * * * * * * * * * | Absorption sensor | 8 |
| * * * * * * * * * * ● * * * * * * * * * * | Wire tampering | Unlimited |
| ● LED OFF (2 seconds) * LED ON (1 second) | | |

3.0 - PIN CODE CUSTOMIZATION

Here below is a step-by-step example showing how to customize the factory set PIN code. In this case the selected PIN code is 5-4-6-7.

NB: For security reasons, the factory set PIN code 1-1-1-1 should be customized.



To carry out the operation successfully, make sure the required electrical connections (door push-button and ignition) have been completed.



If, while entering the PIN code, the LED flashes more than 9 times, the procedure will be interrupted because of an invalid code number.

- With the system disarmed, open the driver side door and keep it open.
- Turn ignition key ON.
- The status LED will light up for 1 sec.; while the LED is ON, simultaneously press remote control buttons 1 and 2.
- A Beep and a Bop will confirm the system is in program mode. The LED will light up.
- Simultaneously press remote control buttons 1 and 2; the LED will power off.
- Cycle ignition key OFF.
- After 4 sec., the status LED will start the first 9-flash sequence.
- At the 5th flash (PIN code 1st digit), press and release the LED button.
- The LED will power off briefly and then start flashing again 9 times.
- At the 4th flash (PIN code 2nd digit) press and release the LED button.
- The LED powers off for approx. 4 sec. and then starts flashing again.
- At the 6th flash (PIN code 3rd digit) press and release the LED button.
- The LED powers off briefly and then starts the last flashing sequence.
- At the 7th LED flash (4th digit) press and release the LED button.

If the code has been entered correctly the system will confirm the end of the procedure by 2 Bops and 1 Beep.

4.0 - EMERGENCY OVERRIDE VIA PIN CODE

In case of an emergency (remote control lost or inoperative), the system can be disarmed by entering the 4-digit PIN code.



If, while entering the PIN code, the LED flashes more than 9 times, the procedure will be interrupted because considered a theft attempt.

To override the system via PIN code, proceed as follows (the code entered in the following example is 5-4-6-7).

- Trigger an alarm condition.
- After the warning signals, approx. 30 sec., the LED powers OFF for approx. 5 sec.
- While the LED is OFF, press and release the button on the status LED.
- The system will enter in emergency disarm mode.
- After approx. 4 sec. the LED will start a 9-flash sequence.
- At the 5th flash (PIN code 1st digit), press and release the LED button.
- The LED will power OFF for approx. 4 sec. and then repeats the flashing sequence.
- At the 4th flash (PIN code 2nd digit), press and release the LED button.
- The LED powers OFF briefly and then starts flashing again.
- At the 6th flash (PIN code 3rd digit) press and release the LED button.
- The LED powers OFF briefly again and then starts the last flashing sequence .
- At the 7th flash (PIN code 4th digit) press and release the LED button.

If the code has been entered correctly, the system will disarm with 3 Beeps and 3 flashes of the turn indicators. An incorrect code, on the other hand, will trigger an alarm. In this case the entire procedure must be repeated.

5.0 - VALET MODE



This setting is used if the self-rearming or passive arming functions have been enabled.

NB: Only for 863 and 862 alarm systems with override key.

Valet mode prevents the system from automatically arming. It is useful when the alarm must be disarmed for vehicle servicing (system configuration will not be affected).

To use valet mode proceed as follows:

- Arm the system and wait for the arming delay period to expire.
- Touch the override key to its receptacle.
- System disarming and disabling of the above mentioned functions will be confirmed by 3 Beeps and 3 flashes of the turn indicators .
- To restore the normal operating mode, arm the alarm via the remote control.

6.0 - CONNECTOR PINOUT

| PIN | WIRE FUNCTION | WIRE COLOUR |
|---------|--|------------------|
| - 1 - | Bonnet switch negative input | GREEN |
| - 1 - | External sensors negative input | GREEN-BLACK |
| - 2 - | Door switch input | GREEN-BROWN |
| - 3 - | Ignition | BLACK marked "G" |
| - 4/5 - | Siren output | ----- |
| - 6 - | Ground | BLACK marked "M" |
| - 7 - | Negative output additional siren, horn or boot release | YELLOW-BLACK |
| - 8 - | Positive output with system armed (+A) | PINK |
| - 9 - | LED and override key receptacle negative output | BLACK and BROWN |
| - 10 - | LED positive output | RED |
| - 11 - | Positive | BLACK marked "R" |
| - 12 - | Antenna | BLACK |
| - 13 - | Override key receptacle input | GREEN |
| - 14 - | Engine block | BLACK marked "H" |
| - 15 - | Engine block | BLACK marked "H" |
| - 16 - | Turn indicators positive/negative output | ORANGE |
| - 17 - | Turn indicators positive/negative output | ORANGE |
| - 18 - | Turn indicators positive/negative common | WHITE-RED |
| - 19 - | Central door locks (CDL) | RED-GREY |
| - 20 - | Central door locks (CDL) | RED-BROWN |
| - 21 - | Central door locks (CDL) | RED-BLUE |
| - 22 - | Central door locks (CDL) | YELLOW-BLUE |
| - 23 - | Central door locks (CDL) | YELLOW-BROWN |
| - 24 - | Central door locks (CDL) | YELLOW-GREY |

7.0 - CONNECTION TO ACTIVATE THE TURN INDICATORS

Connections and programming must be carried out based on the connection mode of the turn indicators (standard or Hazard) given in the installation sheets.

The alarm is factory set to the standard configuration as shown in the first diagram. To modify setting from standard to Hazard, see par. 10.0 (System programming) and proceed as illustrated in the second diagram.

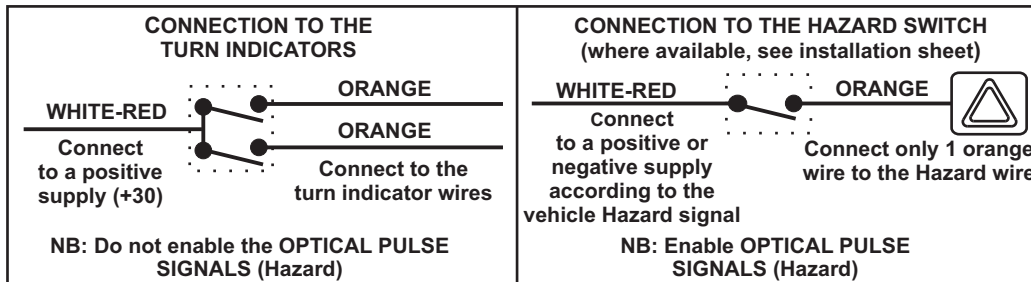

8.0 - WIRING DIAGRAM

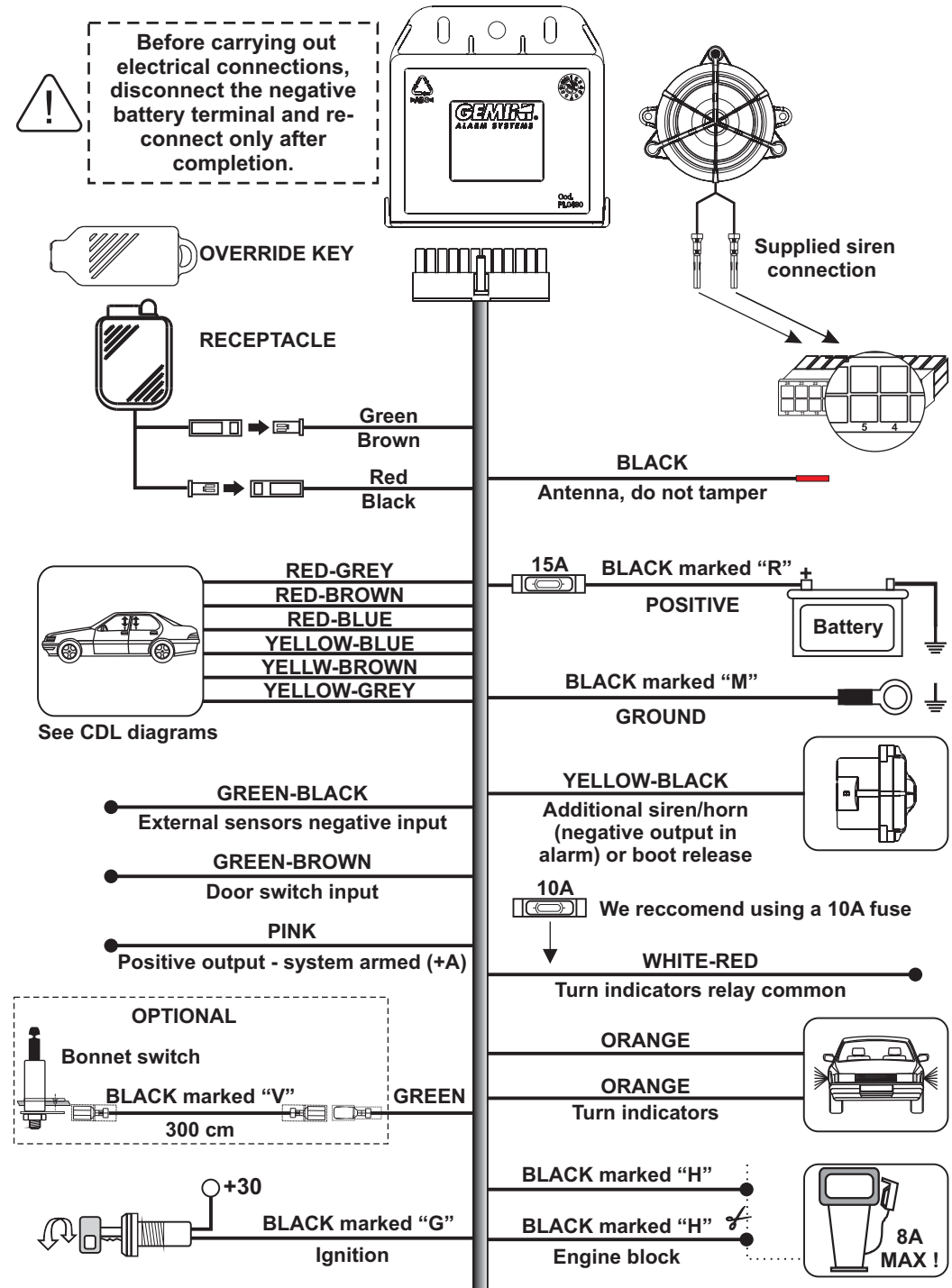



9.0 - PROGRAMMABLE FUNCTIONS

9.1 - ACOUSTIC SIGNALS

This function activates the acoustic signals that confirm system arming/disarming.

9.2 - PANIC ALARM OR CAR-FINDER

Programmable feature (Default setting: panic alarm).

- **Panic alarm:** Press remote control panic button  to trigger siren/flashers for 30 sec.
- **Car-finder:** When the system is armed, press the panic button  to activate the siren/flashers for a few seconds to locate your car.

9.3 - CURRENT ABSORPTION SENSOR

This function triggers an alarm whenever there is a voltage drop in the vehicle electrical circuit. Before enabling the sensor, check out the regulations in force in your country regarding noise pollution.

9.4 - ANTI-DISTRACTION AND AUTO-LOCK

Anti-distraction: prevents the vehicle from being unintentionally left unprotected if, after the system is armed, it is accidentally disarmed by pressing button 2 . The system will automatically rearm after 35 sec. if no other activity is detected (ex. door opening, ignition ON).

Auto-lock: security function that automatically locks all doors approx. 20 sec. after they are all closed and vehicle starts moving. Doors will automatically unlock when ignition is turned OFF.

9.5 - PASSIVE ARMING

If enabled, the system will automatically arm 35 sec. after ignition is switched OFF. Opening a door during the 35-sec. passive countdown will cause the procedure to interrupt; it will resume when the door is closed.

9.6 - DOOR LOCK/UNLOCK PULSE DURATION

This function allows setting the duration of the door lock/unlock output pulses (1 or 6 sec. in duration).

9.7 - COMFORT CONTROL

The comfort feature automatically rolls-up the windows when the system is armed.

9.8 - DOUBLE PULSE UNLOCK

If enabled, 2 unlocking pulses will be supplied to unlock all doors at the same time. This is useful in case separate actions are required to unlock the driver door and then the remaining doors.

9.9 - ADDITIONAL SIREN OUTPUT OR BOOT RELEASE

This function, depending on connections and configuration, allows triggering the additional siren or releasing the trunk by pressing remote control button 4 .

9.10 - NEGATIVE OUTPUT SELECTION (DURING ALARM) FOR HORN OR ADDITIONAL SIREN

Programmable output used to sound the siren (steady) or the horn (pulsed). (Default setting: siren)
If the vehicle's horn is preferred, this feature changes the output from steady to pulsed, allowing the use of the horn for the alarm's audible responses.

9.11 - DOOR OPEN WARNING SIGNAL DURING ARMING TIME

This function triggers the siren for few seconds if a door is still open during arming.

9.12 - OPTICAL SIGNALING MODE

Standard: Connections are made to the turn indicators.

Hazard: Connections are made directly to the Hazard switch.



Optical signals activated by connection to the Hazard switch ONLY turn ON during an alarm condition.

9.13 - DOOR SWITCH POLARITY SELECTION

This function modifies the alarm input signal (positive or negative) according to the signal generated by the door switch.

10.0 - SYSTEM PROGRAMMING



Make sure not to modify the functions that have been programmed at the time of installation.

The system has been factory configured, to modify the settings proceed as follows:

- Disarm the system and turn ignition key to the ON position.
- The status LED stay will light up for 1 sec.; while the LED is ON, simultaneously press remote control buttons 1 and 2.
- A Beep and a Bop will confirm the system is in programming mode. The status LED will turn ON steady.
- Press remote control button 1 or 2 to set the features and scroll through them. A Beep (button 1) or a Bop (button 2) will confirm each change of setting.



If ignition key is turned OFF the alarm system automatically exits programming mode leaving the remaining functions unvaried.

| | FUNCTION | DEFAULT | BUTTON 1 | BUTTON 2 |
|----|---|-------------------|--------------------------|--------------------------|
| 1 | Arming/disarming acoustic signals | Enabled | Enable | Disable |
| 2 | Panic alarm or CAR-FINDER | Enabled | Enable panic | Enable CAR-FINDER |
| 3 | Current absorption sensor | Disabled | Enable | Disable |
| 4 | Anti-distraction/Auto-lock | Disabled | Enable | Disable |
| 5 | Passive arming | Disabled | Enable | Disable |
| 6 | Door lock/unlock time delay | 1 sec. | Enable 6 sec. | Enable 1 sec. |
| 7 | Comfort control (25 sec.) | Disabled | Enable | Disable |
| 8 | Double pulse unlock | Disabled | Enable | Disable |
| 9 | Additional siren or boot release | Additional siren | Enable boot release | Enable additional siren |
| 10 | Continuous sound (siren) or pulsed sound (horn) | Continuous sound | Pulsed sound (horn) | Continuous sound (siren) |
| 11 | Door open warning signal during arming | Disabled | Enable | Disable |
| 12 | Standard or Hazard optic signaling mode | Standard | Enable Hazard | Enable Standard |
| 13 | Door switch polarity selection | Negative polarity | Enable positive polarity | Enable negative polarity |

- When the last function is configured, 2 Bops and 1 Beep will confirm the end of the programming procedure. The LED will power OFF.
- Turn ignition key to the OFF position.

11.0 - PROGRAMMING NEW DEVICES



To carry out the operation successfully, make sure the required electrical connections (door switch, bonnet switch and ignition) are properly connected.



Storing memory is for 50 devices. Adding an extra device will automatically delete the first device stored in the alarm memory.

To enter in programming mode proceed as follows:

- With the system disarmed, open the driver door and the bonnet and leave them open.



The “**ON-OFF**” operations must be carried out within 4 seconds otherwise the procedure is invalidated.

- Cycle ignition key 4 times within 4 sec. (“**ON-OFF**”-“**ON-OFF**”-“**ON-OFF**”-“**ON**”) ending the cycle with the key in the “**ON**” position.
- 1 Beep and 1 Bop will confirm the system is in learn mode.



Do not close the bonnet otherwise all previously programmed devices will be deleted as described in the next paragraph.

- The system is ready to receive the device codes.
- Depending on which device is to be learned, either press remote control button 1, touch the override key to its receptacle, make the magnetic contact transmit (bring contact and magnet together and then move apart), press the opening detector button, make the wireless infrared sensor or hyper-frequency sensor transmit (see sensor instructions).
- Each time a device is learned a Beep will sound and the status LED will flash briefly.
- Repeat this procedure to program other devices.
- Turn ignition key OFF.
- The end of the procedure is confirmed by a Bop.

12.0 - DELETING PROGRAMMED DEVICES



To carry out the operation successfully, make sure the required electrical connections (door switch, bonnet switch and ignition) are properly connected.

Previously programmed devices can be deleted, clear the memory as follows:

- With system disarmed, open the driver door and the bonnet and leave them open.



The following operations must be carried out within 4 seconds otherwise the procedure is invalidated.

- Cycle ignition key 4 times within 4 sec. (“**ON-OFF**”-“**ON-OFF**”-“**ON-OFF**”-“**ON**”) ending the cycle with the key in the “**ON**” position.
- 1 Beep and 1 Bop will confirm the system is in clear mode.
- Close the bonnet; the LED will turn ON steady .
- Keep the bonnet closed (approx. 8 sec.) to fully clear the memory.



If the bonnet is opened before 8 seconds, devices will not be deleted.

- A Bop will confirm the memory has been cleared. The LED will also power OFF.
- Turn ignition key OFF.

13.0 - ULTRASONIC VOLUMETRIC PROTECTION

13.1 - CONNECTIONS AND POSITIONING

Insert the WHITE connector in the "W" marked socket and the RED connector in the "R" marked socket (see figure below).

Install the ultrasonic sensor cells in the uppermost part of the windscreen internal pillars, away from the air vents and point them towards the center of the rear window.

13.2 - SENSOR ADJUSTMENT

To check the sensor sensitivity level proceed as follows:

- With the alarm system disarmed, roll down the front window approx. 20 cm.
- Set the trimmer to an intermediate position (medium sensitivity).
- Close all doors, bonnet and boot and arm the system.
- During the system arming delay introduce an object in the cabin through the window and move it around; the status LED will turn off to signal a presence.
- If the sensitivity level is too high or too low, readjust the trimmer and repeat the above procedure.

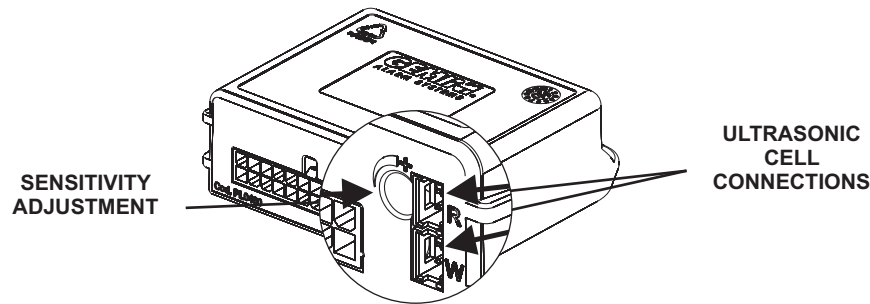

14.0 - SYSTEM RESET



A system reset will return the system to the factory default settings.
This procedure must therefore only be used in case of need.

To reset the system proceed as follows:

- Disconnect the system power supply.
- Press and hold the LED button or short-circuit the RED and BLACK wires of the LED 2-pin connector.
- Connect the system; 4 Beeps and 4 flashes of the turn indicators will confirm the operation.
- Release the LED button or remove the previously created short circuit.
- A flash of the turn indicators and a Beep will confirm the end of the procedure.

15.0 - TECHNICAL SPECIFICATIONS

| | |
|---|---------------|
| Power supply 863 - 862 - 861 | 12 Vdc |
| Power supply 863/24 | 24 Vdc |
| Current absorption @ 12Vdc with system armed and LED flashing | 15 mA |
| Working temperature range | -30°C to +70° |
| Turn indicators relay contact capacity | 8 A @ 20°C |
| Engine immobilizer relay contact capacity | 8 A @ 20°C |
| Alarm cycle duration | 30 sec. |
| Maximum positive current output when armed (+A) | 10 mA |
| Siren output | 5 A |

16.0 - WASTE ELECTRICAL AND ELECTRONIC EQUIPMENT

The present device falls within the field of application of the current WEEE Directive. The crossed-out wheeled bin symbol on the equipment or on its packaging indicates that the product, at the end of its useful life, must be discarded separately from other waste to allow adequate treatment and recycling. The user must therefore take the equipment, at the end of its useful life, to an appropriate waste collection facility.

