

INSTALLATION CERTIFICATE

The undersigned qualified installer attests having personally fitted the alarm system on the vehicle specified below, following the manufacturer's instructions.

By :

Sold on :

Type of device : 972

Vehicle :

GEMINI Technologies S.p.A.
Via Luigi Galvani 12 - 21020 Bodio Lomnago (VA) - Italia
Tel. +39 0332 943211 - Fax +39 0332 948080
Web site: www.gemini-alarm.com



972AR

INSTALLATION AND USE MANUAL



Made in Italy

AC 2791/UK Rev. 01 - 11/10

1.0 - PRELIMINARY ADVICE..... PAGE 02
2.0 - TECHNICAL DATA..... PAGE 02

USER MANUAL

3.0 - OPERATING DESCRIPTION..... PAGE 03
 3.1 - System arming..... PAGE 03
 3.2 - Arming inhibit time..... PAGE 03
 3.3 - System armed..... PAGE 03
 3.4 - Alarm, inhibit time between alarms and alarm cycles..... PAGE 03
 3.5 - System disarming..... PAGE 03
4.0 - GARAGE FUNCTION..... PAGE 03
5.0 - ANTI-HIJACK FEATURE..... PAGE 04
 5.1 - Vehicle running: normal functioning..... PAGE 04
 5.2 - Vehicle running: agression and hijack..... PAGE 04
 5.3 - Vehicle running: anti-hijack activation..... PAGE 04
 5.4 - Deactivation of anti-hijack feature..... PAGE 04
6.0 - TAG CARD ACTIVATION AND BATTERY REPLACEMENT..... PAGE 05
7.0 - WARRANTY CONDITIONS..... PAGE 05

INSTALLER MANUAL

8.0 - CONNECTOR TABLE..... PAGE 06
9.0 - COMPLETE ELECTRIC DIAGRAM..... PAGE 07
10.0 - ADDING NEW DEVICES..... PAGE 08
11.0 - DELETING OF PROGRAMMED DEVICES..... PAGE 09
12.0 - WASTE ELECTRICAL AND ELECTRONIC EQUIPMENT (WEE) DIRECTIVE..... PAGE 09

1.0 - PRELIMINARY ADVICE

Dear customer,
 The following signs are intended to draw user and installer attention to particular functions or connections as follows:



Indications useful for the user.

This icon provides the user with indications for a diversified use of the system or it simply provides indications useful for the use.



Indications useful for the installer.

This icon indicates to the installer a diversified operating, according to the connection and the programming of the system or it simply provides indications useful for the installation.

2.0 - TECHNICAL DATA

Operating power	12 Vdc
Current absorption @ 12Vdc with system armed and LED flashing	Less than 15 mA
Operating temperature range	From -30°C to +70°C
Turn signals relay contact capability	8 A to 20°C
Engine immobilisation relay contact capability	8 A to 20°C
Alarm cycle	30 sec.
Horn output current capacity	5 A

3.0 - OPERATING DESCRIPTION

3.1 - SYSTEM ARMING

The system arms automatically 30" after turning off the engine (lack of ignition key contact) as long as no TAG transmission is detected.
 Opening a door 30" before the system is armed temporarily interrupts the procedure which will resume once the door is closed.

3.2 - ARMING INHIBIT TIME

The inhibit arming time lasts for approximately 8" and is indicated by the status LED turning ON steady; during this period it's possible to exit the vehicle without triggering any alarm.

3.3 - SYSTEM ARMED

After the inhibit time the system is "armed" and it is ready to detect any theft attempt.
 When the system fully armed, the LED flashes.

3.4 - ALARM, INHIBIT TIME BETWEEN ALARMS AND ALARM CYCLES

Before any audio/visual signalling of the alarm occurs there is a 16" pre-alarm neutral time (LED steady ON).

The system indicates theft attempts by visual/audio signals (flashing of the turn indicators and intermittent sounding of the vehicle horn).

After the alarm event, but before another alarm is triggered, there is a 5" neutral time.
 The alarm signalling has 5 cycles of 30" each for each input and for each arming cycle.

3.5 - SYSTEM DISARMING

If the system is armed, it will start disarming upon detecting your TAG; the disarming procedure will then be completed when the driver door is opened.

4.0 - GARAGE FUNCTION



This garage feature "deactivates" the system and is useful when the vehicle is in a workshop for maintenance or repairs or if the TAG CARD is not working.

The garage feature can be activated with system armed or disarmed by inserting the electronic key in its receptacle while the driver door is opened.

System deactivation is indicated by three acoustic signals of the buzzer.

To reactivate the system simply introduce the electronic key in its receptacle.

System activation is indicated by an acoustic signal of the buzzer.

To activate the garage feature during an alarm condition or during a hijack attempt (vehicle running) simply introduce the electronic key in its receptacle (door either opened or closed).



When the "garage feature" is ON, the status LED blinks twice followed by a 2 seconds pause.

5.0 - ANTI-HIJACK FEATURE



Arming the anti-hijack feature means that only TAG reception and identification is activated and not vehicle immobilization.

The 972AR module has an anti-hijack feature for protection against aggression or vehicle theft. It operates by means of an automatic transmitter (TAG), which communicates with the 972AR module via a codified radio signal. When ignition is turned OFF, the module arms and works as an alarm and the TAG as a remote control. When the vehicle is running and there is no TAG transmission, the alarm system activates the anti-hijack procedure, as described further on.



For security reasons, we recommend you keep your electronic key and TAG separate from your ignition key so that, if your vehicle is robbed, you have your electronic key and TAG with you.

This feature can be activated even if the vehicle is turned OFF; if it is turned ON and the system does not detect the TAG, the anti-hijack feature arms.

5.1 - VEHICLE RUNNING: NORMAL OPERATION

Under this condition, the system only detects TAG transmission and the LED does not blink.

5.2 - VEHICLE RUNNING: AGGRESSION AND HIJACKING

As already mentioned, in case of car theft, the user should still have his TAG with him. If the door is opened and the driver walks away with the TAG, the module no longer detects radio contact and enters, after 60", in pre-arm mode.

5.3 - VEHICLE RUNNING: ANTI-HIJACK ACTIVATION

The turn indicators and the buzzer, siren or the horn (if connected) will activate for 2 minutes. 20" after the audio/visual signals, the vehicle immobilizer will activate (20" ON/OFF up to a complete stop). If the driver doesn't turn them off, the turn indicators will keep flashing for 3 hours while the siren or horn will sound for two minutes.

5.4 - DEACTIVATION OF ANTI-HIJACK FEATURE

To deactivate the anti-hijack feature all the driver has to do is walk up to his vehicle with the TAG. The module, on intercepting the signal, will deactivate the anti-hijack feature and stop the optic and acoustic alarm signals. Deactivation of the anti-hijack feature with electronic key will arm the "garage function" (see par. 4.0).

6.0 - TAG CARD ACTIVATION AND BATTERY REPLACEMENT

To activate the TAG CARD simply press the button and keep it pressed for at least 4 seconds. The LED turns on steady when the TAG is activated and it will flash each time the TAG transmits. If not moved for 10 min., the TAG will automatically go into standby to save battery life; to 'wake it up' for another transmission cycle (10 min.), move it or press the button. Another short button press will send a radio signal to the alarm system. To turn the TAG off, press the button and keep it pressed for at least 8 seconds. The LED stays on steady and after 8 seconds it will flash briefly to indicate the TAG is switched off. To replace battery proceed as follows:

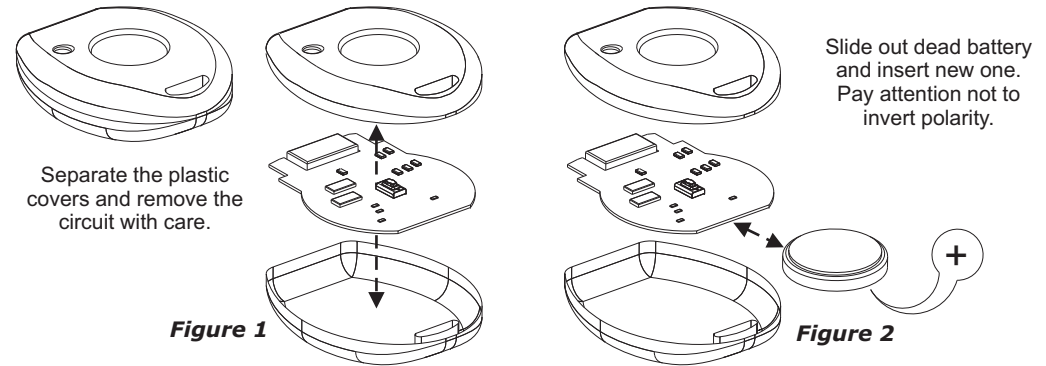

Figure 1

Figure 2

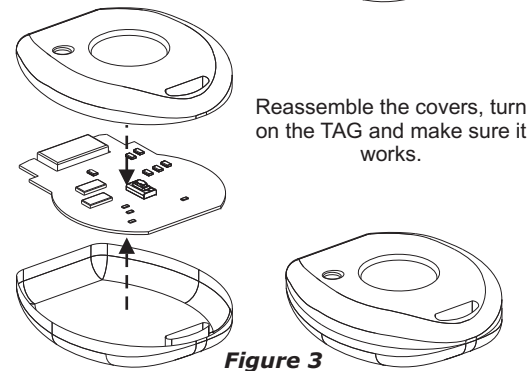

Figure 3



Use ONLY CR2032 type battery; do not discard used batteries in trash but safely dispose in appropriate containers.

7.0 - WARRANTY CONDITIONS

This product is guaranteed to be free from defects in workmanship for a period of 24 months from the date of installation reported on this warranty, in compliance with the 1999/44/CE Warranty Directive (L.D. N° 24 of the 02/02/2002).

Please fill-in entirely the guarantee certificate included in this booklet and DO NOT REMOVE the guarantee label from the device.

The warranty will become void if labels are missing or torn, if the installation certificate is not fully compiled or if the enclosed sale document is missing.

The warranty is valid exclusively at Authorized Gemini Centers.

The manufacturer declines any responsibility for eventual malfunctions of the device or any damage to the vehicle electrical system due to improper installation, use or tampering.

This alarm is solely intended to be a theft-deterrent device.

INSTALLER MANUAL

8.0 - CONNECTOR TABLE

POSITION	WIRE FUNCTION	WIRE COLOR
- 1 -	Negative input for new devices programming	GREEN
- 2 -	Doors push-button negative input	GREEN-BROWN
- 3 -	Positive under key	BLACK marked "G"
- 4 -	-----	-----
- 5 -	-----	-----
- 6 -	Ground	BLACK marked "M"
- 7 -	Horn negative output	YELLOW-BLACK
- 8 -	Buzzer negative output	GREEN-RED
- 9 -	Ground for LED and receptacle for electronic key	BLACK and BROWN
- 10 -	LED positive output	RED
- 11 -	Positive	BLACK marked "R"
- 12 -	Antenna	BLACK
- 13 -	Input receptacle for electronic key	GREEN
- 14 -	Engine Immobilization	BLACK marked "H"
- 15 -	Engine Immobilization	BLACK marked "H"
- 16 -	Turn indicators output	ORANGE
- 17 -	Turn indicators output	ORANGE
- 18 -	Turn indicators output common	WHITE-RED
- 19 -	-----	-----
- 20 -	-----	-----
- 21 -	-----	-----
- 22 -	-----	-----
- 23 -	-----	-----
- 24 -	-----	-----

 To activate the anti-carjack feature, the positive under key (BLACK wire marked "G") and the door push-button (GREEN-BROWN) MUST be connected. We recommend you ALWAYS make these connections.

9.0 - COMPLETE ELECTRIC DIAGRAM

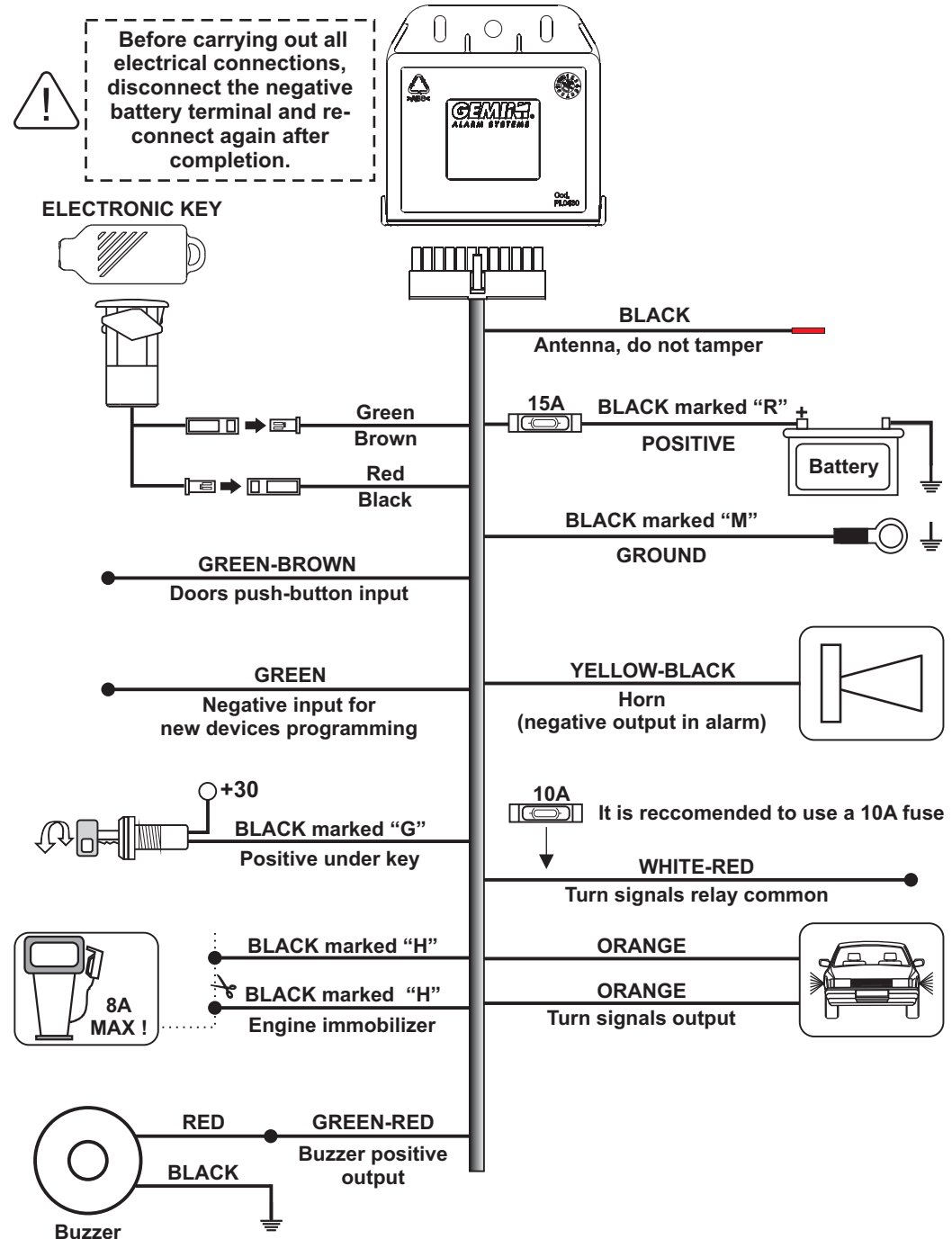

10.0 - ADDING NEW DEVICES



To carry out this operation successfully, you must first make the required electrical connections (door switch, GREEN wire to ground and and positive under key).

The system can record a maximum of 11 devices, either electronic keys or TAG CARDS. To activate the procedure follow the indications reported below.

- With the alarm system disarmed, open and keep opened the driver door and connect to ground the GREEN wire.



The following operations must be carried out within four seconds otherwise the procedure is invalidated.

- Turn ignition key over 4 times: “ON-OFF”-“ON-OFF”-“ON-OFF”-“ON”.
- At the fourth rotation, keep ignition key “ON”.
- The buzzer will chirp twice and the turn indicators will flash twice to indicate the learning procedure of new devices has started.



Do not close the driver door otherwise the devices already saved will be deleted as described in the next paragraph.

- The system is now ready to receive the device codes.
- Depending on the device to be recorded, either insert the electronic key into its receptacle or let the system pick up the TAG signal.
- To indicate the new device is learned, the buzzer chirps once and the status LED blinks once.
- Repeat the above steps to record other devices.
- Turn ignition key to “OFF”, close the door and remove from ground the GREEN wire
- When the procedure is completed, the siren buzzer once.



Storing memory is for 11 devices. If you store an extra one it will automatically delete the first device recorded in the system memory.

11.0 - DELETING PROGRAMMED DEVICES



To carry out this operation successfully, you must first make the required electrical connections (door switch, GREEN wire to ground and and positive under key).

The system has a delete mode to remove a programmed electronic key or TAG CARD. To activate the procedure follow the indications reported below.

- With the alarm system disarmed, open and keep opened the driver door and connect to ground the GREEN wire.



The following operations must be carried out within four seconds otherwise the procedure is invalidated.

- Turn ignition key over 4 times: “ON-OFF”-“ON-OFF”-“ON-OFF”-“ON”.
- At the fourth rotation, keep ignition key “ON”.
- The buzzer will chirp twice and the turn indicators will flash twice to indicate that the delete procedure has been initiated.
- Close the door; the LED turns on steady.
- Keep the bonnet closed for at least 8 seconds until all the devices are cancelled.



The devices will not be deleted if the door is opened before 8 seconds.

- When this procedure is completed, the LED turns off, the buzzer chirps once and the turn indicators flash once.
- Turn ignition key to “OFF” and disconnect from ground the GREEN wire.

12.0 - WASTE ELECTRICAL AND ELECTRONIC EQUIPMENT (WEEE) DIRECTIVE

In the European Union, this label indicates that this product should not be disposed of with household waste. It should be deposited at an appropriate facility to enable recovery and recycling (directive 2002/95/CE, 2002/96/CE and 2003/108/CE).

For information on how to recycle this product responsibly in your Country, please visit the web-site: www.eur-lex.europa.eu



APPROPRIATE
CONTAINER ONLY